

KSH

tüv
CERT

DIN EN ISO 9001-2008

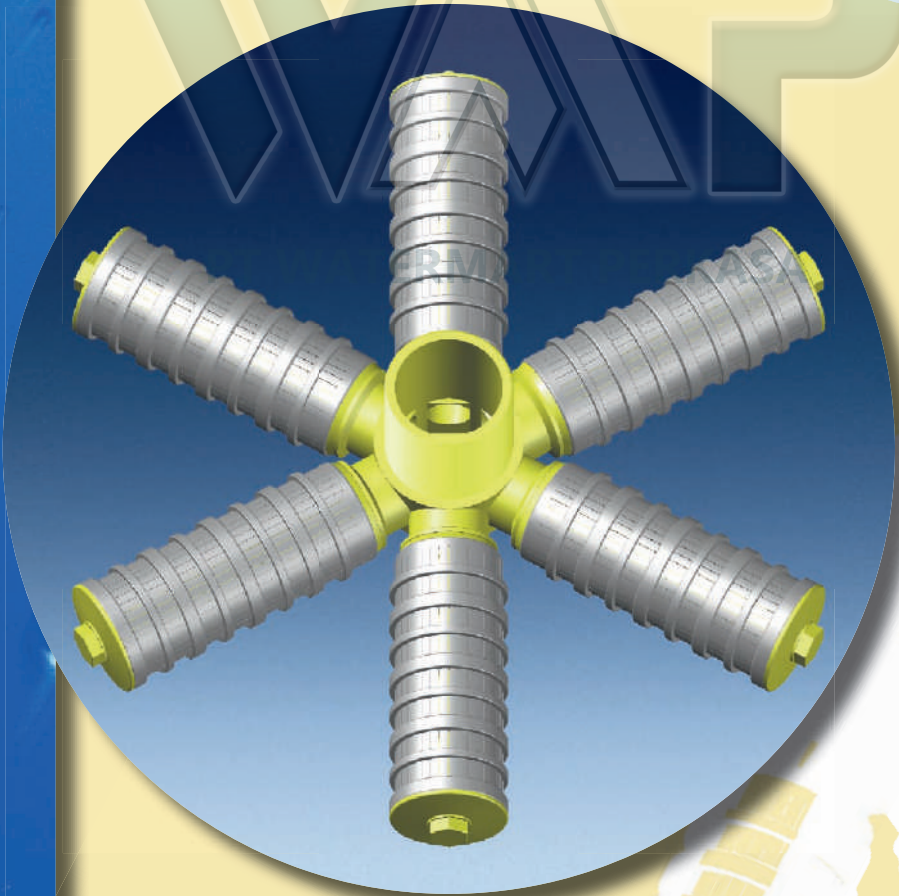

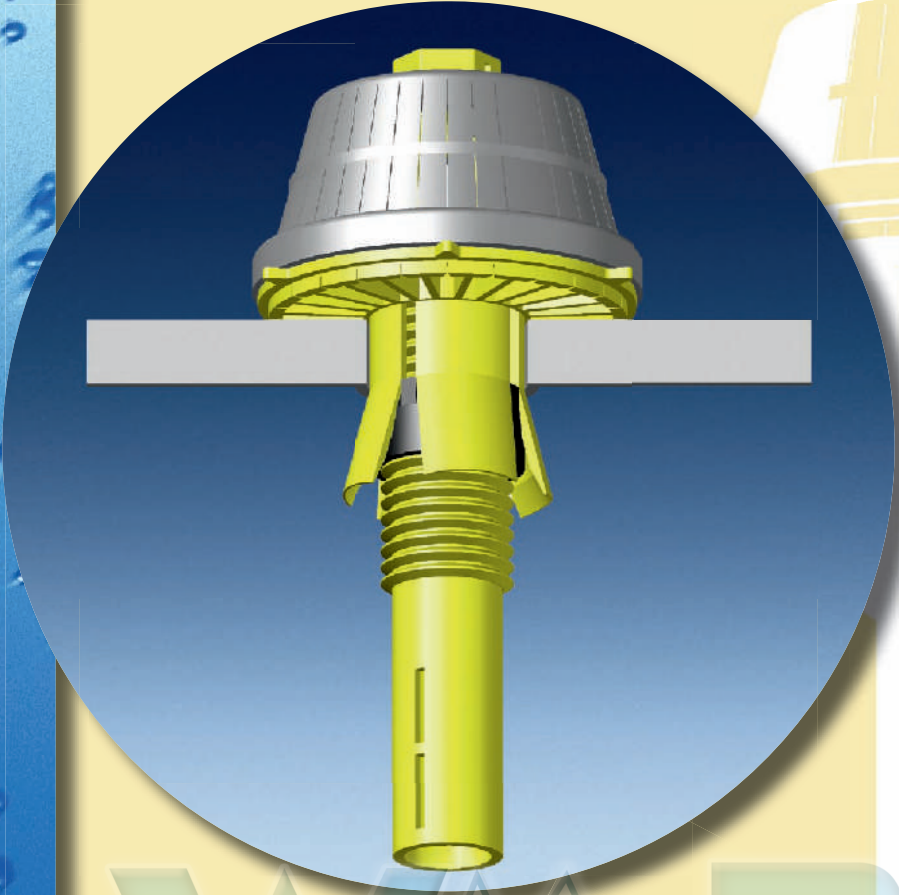

Filterdüsen

Für Wasser und Abwasser-
Aufbereitung

Filter-Nozzles

For water processing and water
cleaning

Crépines à filtre

Pour le traitement et
la filtration de l'eau

Toberas filtrantes

Para el tratamieto y la
filtration del agua



Filterdüsen-Sterne

Filter-Nozzles-Stars

Crépines étoiles

Estrellas para toberas a filtro



Material- beständigkeit	Constancy of the material	Résistance du matériel	Resistencia del Material
Unsere Filterdüsen und Filterdüsensterne werden aus Polypropylen hergestellt. Polypropylen (PP) ist in Abhängigkeit vom Druck zum Beispiel beständig bei 60°C (333 K) gegen:	Our Filter nozzles and Filter nozzles-stars are made of polypropylene. Depending on the drop in pressure for example at 60°C (333 K) Polypropylene (PP) is resistant against:	Nos crépines à filtre sont fabriquées en polypropylène. Le polypropylène (PP) résiste, en fonction de la pression, par exemple à 60°C (333 K) aux produits suivants:	Nuestras toberas y estrellas filtrantes están fabricadas en polipropileno (PP). Dependiendo de la presión puntual de entrada y por ejemplo a 60°C (333 K), el polipropileno es resistente a:
Ammoniak w 10 % Formaldehyd w 10 % Isopropanol w jede Methanol w 50 % Natronlauge 50 % Salzsäure 50 % Schwefelsäure 50 % Sodawasser Ozon 20°C, 50 pphm (0,5mg/L)	ammonia ag 10 % formaldehyde ag 10 % isopropanol all concentrations methanol ag 50 % caustic soda solutions 50 % hydrochloric acid 50 % sulfuric acid 50 % soda water ozone 20°C, 50 pphm (0,5mg/L)	ammoniaque aq 10 % formaldéhyde aq 10 % isopropanol aq toute concentration méthanol aq 50 % solution de soude 50 % acide chlorhydrique 50 % acide sulfurique 50 % eau soda ozone 20°C, 50 pphm (0,5mg/L)	amoníaco, sol. 10 % formaldehído, sol. 10 % isopropanol, cualquier conc. metanol, sol. 50 % sosa cáustica, sol. 50 % ácido clorhídrico, conc. 50 % ácido sulfúrico, conc. 50 % agua de soda Ozono 20°C, 50 pphm (0,5mg/L)
Polypropylen ist physiologisch unbedenklich.	Polypropylene is physiologically unobjectionable.	Le polypropylène est physiologiquement neutre.	El polipropileno es inocuo.
Polypropylen wird bei zunehmenden Frost spröder. Bitte, behandeln Sie Produkte aus PP entsprechend. Bei Kälte empfehlen wir die Filterdüsen und Mutter vor der Montage zu erwärmen.	With increasing frost polypropylene gets more sensitive. Please, handle all articles made of polypropylene accordingly. If it is cold we recommend to warm up filter nozzles and nuts before installation.	Le polypropylène devient plus cassant en cas de gel croissant. Veuillez traiter les produits en polypropylène en tenant compte de ce facteur. Lors de basse température nous recommandons le réchauffement des crépines à filtre ainsi que des écrous avant le montage.	A bajas temperaturas la fragilidad del polipropileno aumenta. Deben utilizarse los productos fabricados en PP, teniendo en cuenta la anterior circunstancia. En caso de bajas temperaturas, recomendamos calienten las toberas filtrantes y tuercas antes de su montaje.
Für Heißwasser bis max. 110°C empfehlen wir in Abhängigkeit vom Druck Polypropylen mit chemisch gekoppelter 30% Glasfaser (PP GV 30 S). Mit dem Einsatz von PPGV30s ändern sich die angegebenen Maße. Bitte bei Bedarf nachfragen.	For hot water of a continuous temperature of up to max. 110°C depending on the drop in pressure we recommend polypropylene with chemically combined 30% glass fibres. Using PPGV30s, the indicated measurements may change. If required, please contact us for information.	Pour de l'eau chaude à température constante allant jusqu'à 110°C max., nous recommandons l'utilisation du polypropylène chargé à 30% de fibres de verre. Pour le PPGV30s, Les dimensions indiquées peuvent changer. Les cas échéant, n'hésitez Pas à nous contacter pour plus d'informations.	Para agua caliente a temperatura constante hasta un máx. de 110°C, y dependiendo de la presión puntual de entrada, recomendamos utilizar nuestras toberas fabricadas en PP reforzadas con el 30% de fibra de vidrio. Utilizando PPGV30s, las medidas indicadas pueden variar. En caso necesario, le pedimos que contacten con nosotros para especificaciones.
Für Heißwasser bis max. 135°C empfehlen wir in Abhängigkeit vom Druck PVDF. (Bedingt beständig gegen konzentrierte Laugen).	For hot water of a continuous temperature of up to max. 135°C depending on the drop in pressure we recommend PVDF. (Conditionally resistant to concentrated caustic solutions).	Pour de l'eau chaude à température constante allant jusqu'à 135°C max., nous recommandons l'utilisation du PVDF (résistance limitée aux solutions concentrées).	Para agua caliente a temperatura constante hasta un máx. de 135°C, dependiendo de la presión puntual de entrada, recomendamos utilizar nuestras toberas fabricadas en PVDF. Resisten soluciones concentradas de bases fuertes (con restricciones).
Farben für Schlitz (PP): 0,2 = elfenbein 0,3 = grün 0,35 = weiß 0,5 = grau 0,7 = gelb 0,8 = blau 1,0 = schwarz 1,5 = orange 2,0 = grün	Colour of slots (PP): 0,2 = ivory 0,3 = green 0,35 = white 0,5 = grey 0,7 = yellow 0,8 = blue 1,0 = black 1,5 = orange 2,0 = green	Coloration par fente (PP): 0,2 = ivoire 0,3 = vert 0,35 = blanc 0,5 = gris 0,7 = jaune 0,8 = bleu 1,0 = noir 1,5 = orange 2,0 = vert	Color de las ranuras (PP): 0,2 = marfil 0,3 = verde 0,35 = blanco 0,5 = gris 0,7 = amarillo 0,8 = azul 1,0 = negro 1,5 = naranja 2,0 = verde
Anzugsmoment siehe Montageanleitungen	Tightening torque see at Installation-instruction	couple de serrage voir instructions de montage	Par de apriete en el manual de instrucciones
1 mWS = ca. 0,1 bar	1 mWS = approx. 0,1 bar	1 m de colonne d'eau = env. 0,1 bar	1 mWS = aprox. 0,1 bar
Gewinde in Anlehnung an DIN ISO 228 für G, BSP ANSI B1.20.1-1983 für NPT, NPSM ANSI B1.1a-1984 für UN	Threads in the approach of DIN ISO 228 for G, BSP ANSI B1.20.1-1983 for NPT, NPSM ANSI B1.1a-1984 for UN	Les fils dans l'approche de DIN ISO 228 pour G, BSP ANSI B1.20.1-1983 pour NPT, NPSM ANSI B1.1a-1984 pour UN	Número aproximado hilos de rosca según DIN ISO 228 para G, BSP ANSI B1.20.1-1983 para NPT, NPSM ANSI B1.1a-1984 para UN
Maße in mm.	Dimensions in mm.	Dimension en mm.	Dimensiones en mm.
Irrtümer / Druckfehler Technische Änderungen vorbehalten.	Error / Pressure Failure We reserve the right to alter specifications.	Sous réserve de fautes ou d'erreurs d'impression et de modifications techniques.	Error / Fallo de Presión Nos reservamos el derecho de alterar las especificaciones técnicas.
Alle technischen Informationen verstehen sich ohne jede Gewähr. Es gelten die Angaben des jeweils angeforderten Datenblattes.	No responsibility is taken for the correctness of the technical information. Only specifically provided data sheets are valid.	Toutes les informations techniques sont sans garantie. Seules les fiches techniques spécifiquement fournies au client sont valables.	Todos informaciones técnicas son sin garantía. Solamente nuestras hojas de datos específicos directamente transmitidos al cliente son válidos.

Anwendungs-
beispiele (Inhalt)

Contents and
typical applications

Sommaire
mode d'emploi

Ejemplos de
aplicacion indice

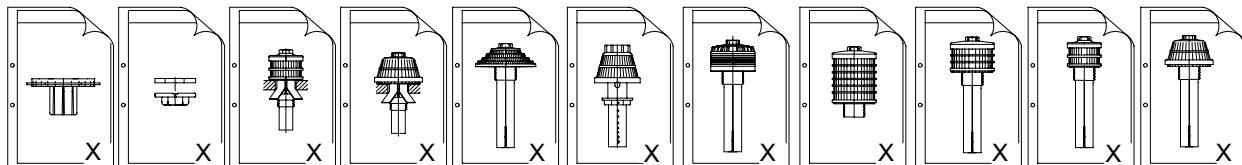
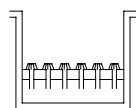
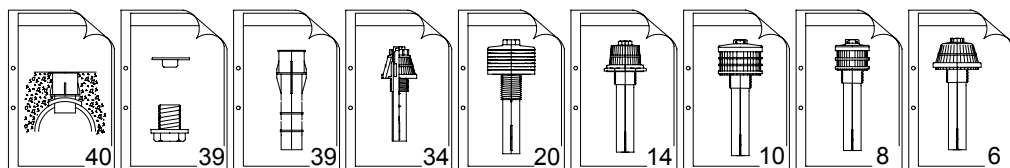

X = 6-23 / 34-35

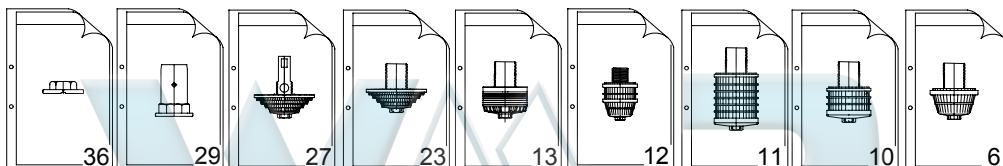
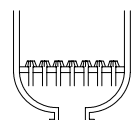

PT WATERMART PERKASA

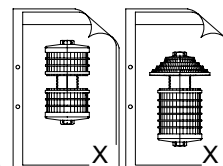

X = 30-31

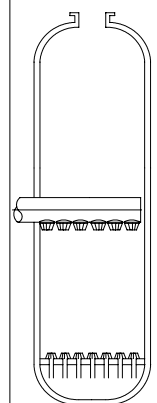
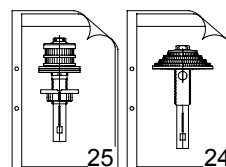
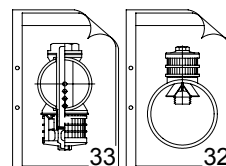
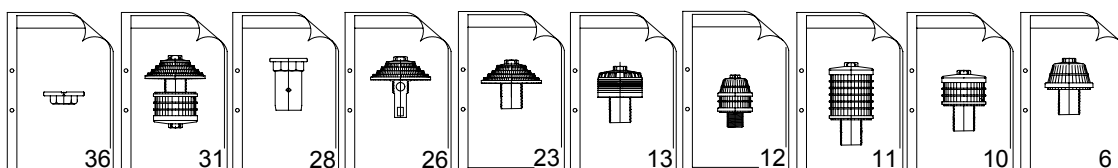
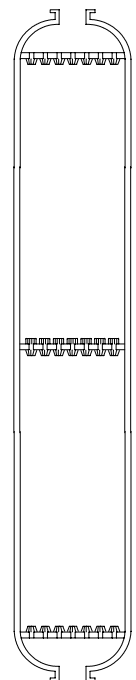

Anwendungs-
beispiele (Inhalt)

Contents and
typical applications

Sommaire
mode d'emploi

Ejemplos de
aplicacion indice

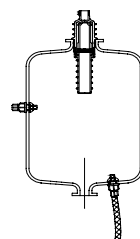
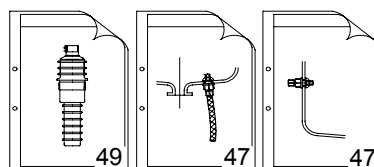
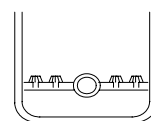
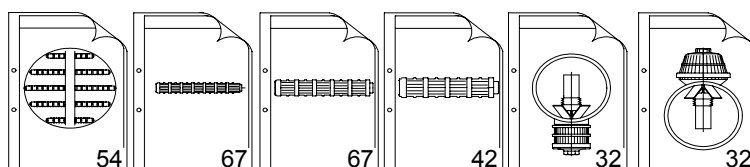
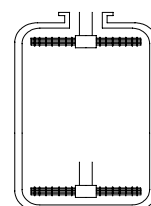
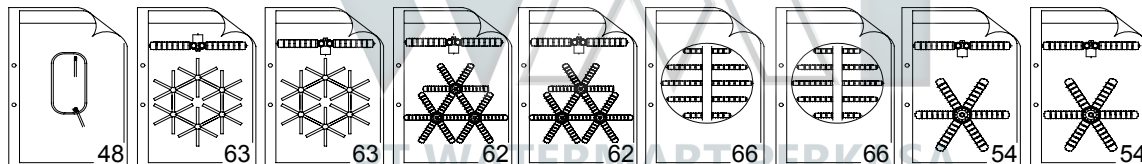
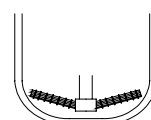
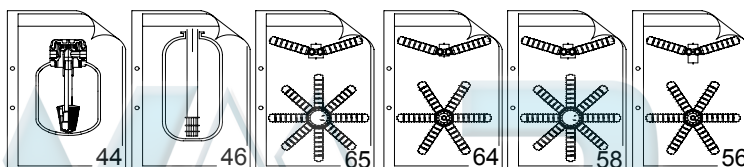
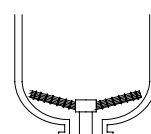
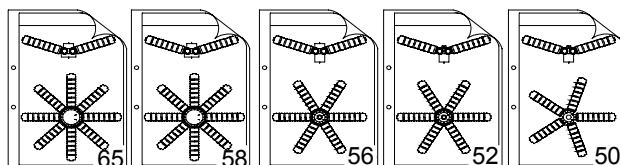
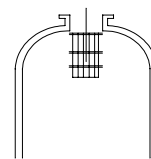
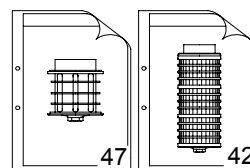

Filterdüsen

Filter-Nozzles

Crépines à filtre

Toberas filtrantes

Typ K1 / KR1

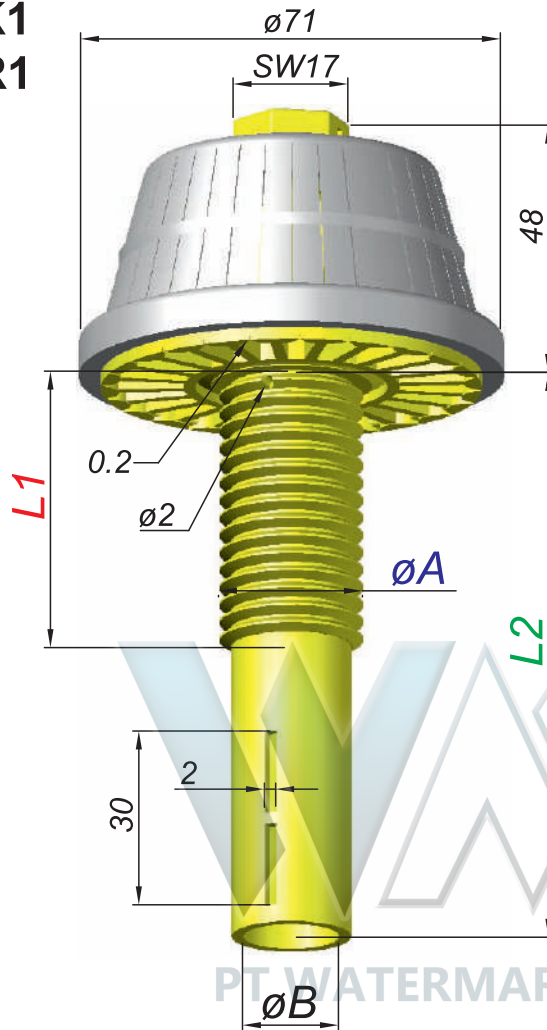

Typ K1

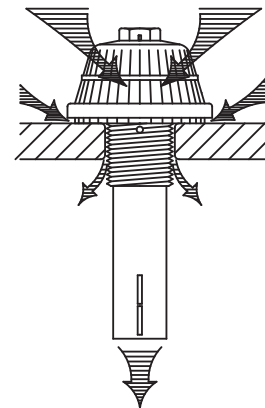

Typ KR1

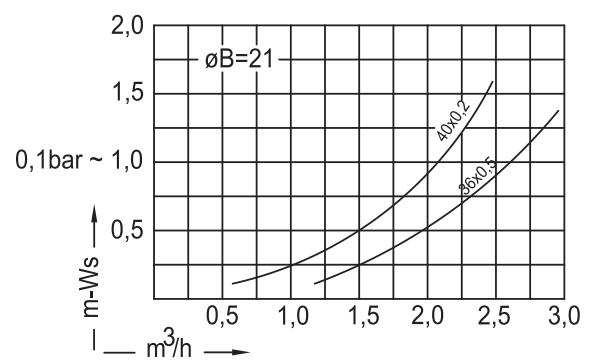
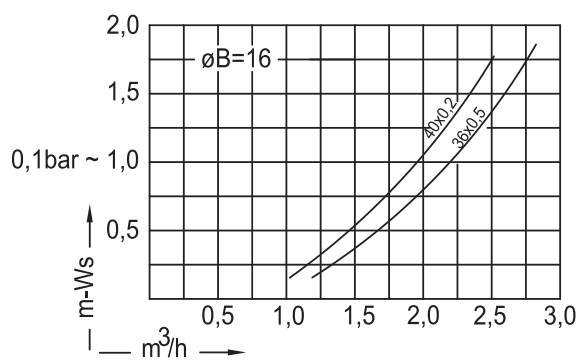
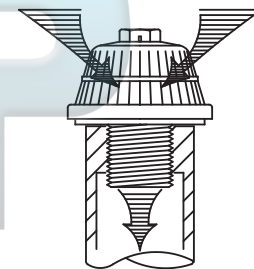

Bestellung Ordering Commande Encargo	Typ Type Type Tipa	Schlitze Slots Fentes Ranuras	Gewinde Thread Filetage Rosca	øA	Gewindelänge Thread length Longueur de filetage Largura de la rosca	Schaft Shaft Longueur de tige Tija	øB			
	K1 KR1	40x0,2 = 1,95 cm ² 36x0,35 = 2,96 cm ² 20x0,5 = 2,35 cm ² 36x0,5 = 4,23 cm ² 20x0,8 = 3,78 cm ² 36x1,0 = 8,46 cm ² 24x1,5 = 7,05 cm ² 20x2,0 = 9,50 cm ²	G1"	33,25	20	80, 110, 140, 200, 250, 300, 350, ...	21 = 3,4 cm ²			
			1 1/4" WW	32	20, 30, 45, +5+5...					
			M30 x 3.5	30	30					
						G3/4"	26,5	20, 30, 45, +5+5...	80, 110, 140, 200, 250, 300, 350, ...	16 = 2,0 cm ²
			1" WW	25,4	20, 45, +5+5...					
			M24	24	25, 45, +5+5...					
						M22 x 1,5	22	45, +5+5...	80, 110, 140, 200, ...	13 = 1,3 cm ²
			G1/2"	21	15, 20, 40					
			M20	20	45, +5+5...					
						G3/8"	16,7	20		

Filterdüsen

Filter-Nozzles

Crépines à filtre

Toberas filtrantes

Typ KSP

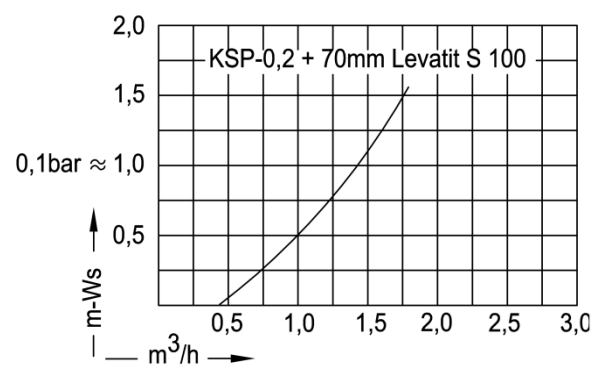
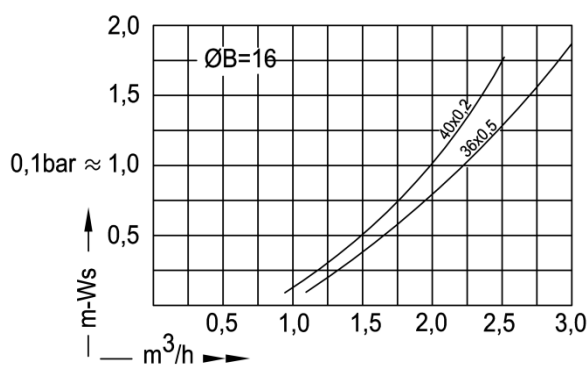
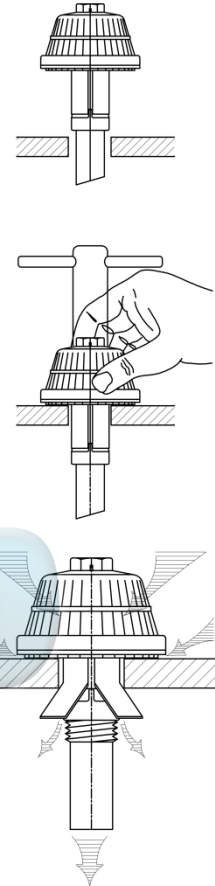
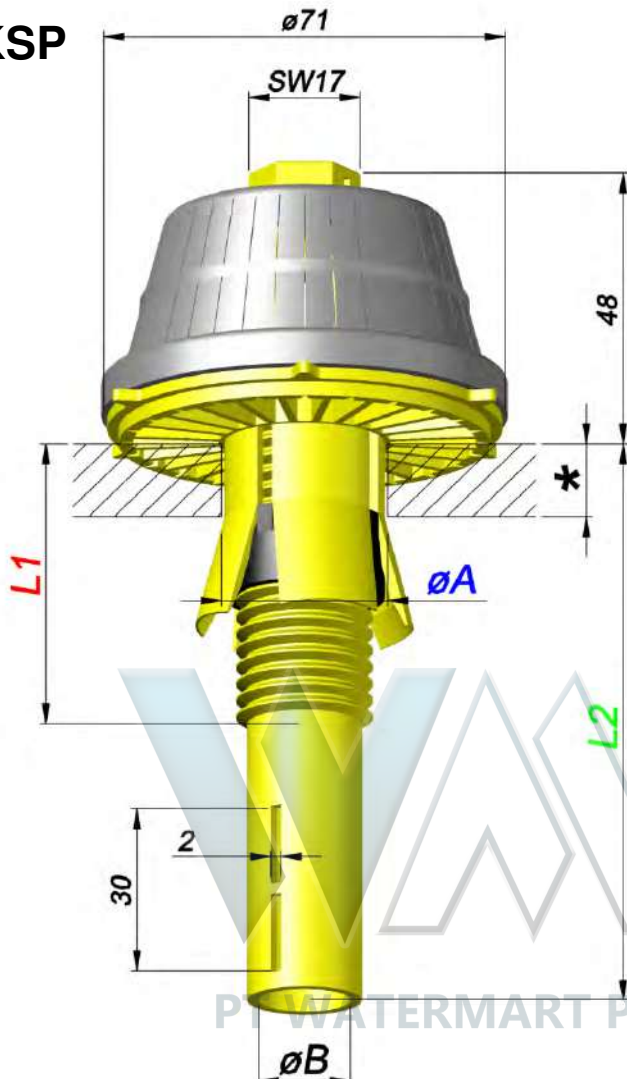

Bestellung Ordering Commande Encargo	Typ Type Type Tipa	Schlitze Slots Fentes Ranuras	*	L1	Schaft Shaft Longueur de tige Tija	L2	øA	øB
✉	KSP	40 x 0,2 = 1,95 cm²	8 - 28	50	80, 110, 140, 200, 250		28-29,5; 29,5-31,5; 31,5-33;	16 = 2,0 cm²
		36 x 0,35 = 2,96 cm²	25 - 45	73	110, 140, 200, 250		33-34,5; 34,5-36;	
		20 x 0,5 = 2,35 cm²						
		36 x 0,5 = 4,23 cm²	8 - 28	50	80, 110, 140, max. 200		25-27,5 ; 26,5-28,5	13 = 1,3 cm²
		20 x 0,8 = 3,78 cm²	25 - 45	73	80, 110, 140, max. 200			
		36 x 1,0 = 8,46 cm²						
24 x 1,5 = 7,05 cm²								
		20 x 2,0 = 9,50 cm²						

Filterdüsen

Filter-Nozzles

Crépines à filtre

Toberas filtrantes

Typ D

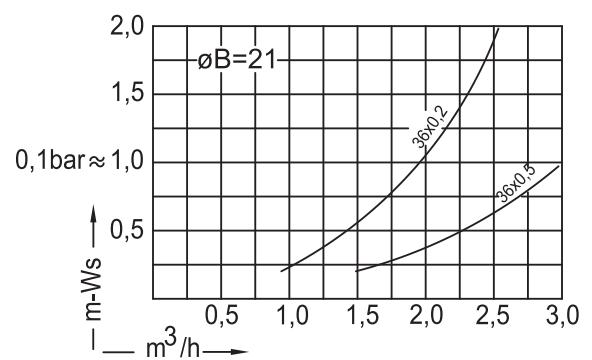
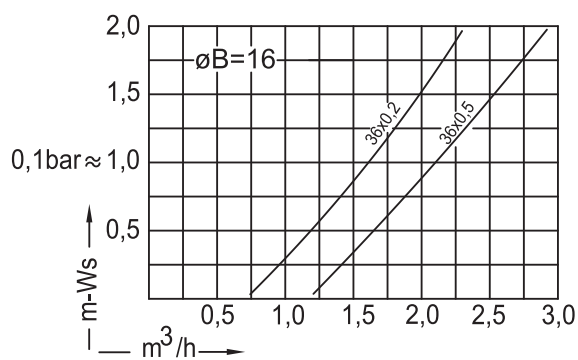
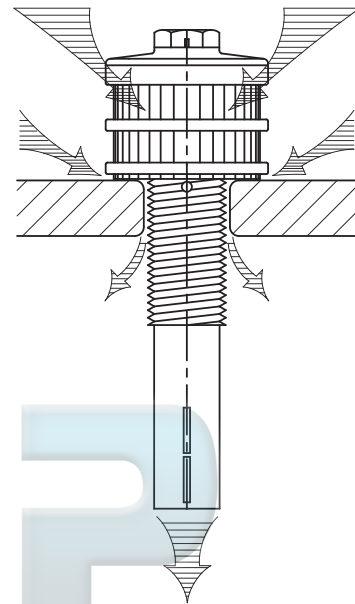
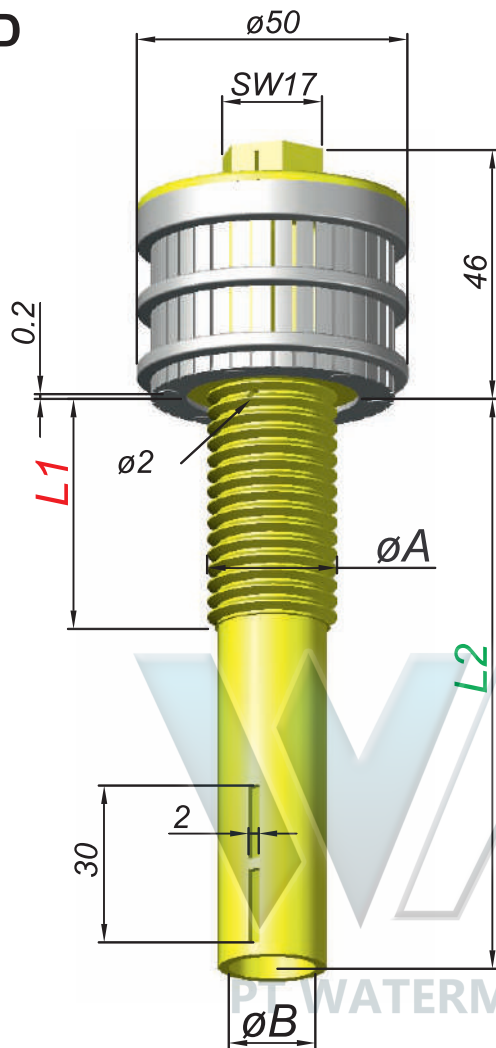

Bestellung Ordering Commande Encargo	Typ Type Type Tipa	Schlitze Slots Fentes Ranuras	Gewinde Thread Filetage Rosca	ϕA	Gewindelänge Thread length Longueur de filetage Largura de la rosca	Schaft Shaft Longueur de tige Tija	ϕB	
	D	24 x 0,2 = 0,91 cm ²	1¼"WW	32	20, 30, 45, +5+5...	80, 110, 140, 200, 250, 300, 350, ...	21 = 3,4 cm ²	
		36 x 0,2 = 1,37 cm ²	M30 x 3.5	30	30			
		36 x 0,3 = 2,05 cm ²	G 3/4"	26,5	20, 30, 45, +5+5...			
		36 x 0,4 = 2,74 cm ²	1"WW	25,4	20, 45, +5+5...			
		36 x 0,5 = 3,42 cm ²	M24	24	25, 45, +5+5...		16 = 2,0 cm ²	
		36 x 0,8 = 5,46 cm ²	M22 x 1,5	22	45, +5+5...			
		24 x 1,0 = 4,56 cm ²	G 1/2"	21	20			
		24 x 1,5 = 6,84 cm ²	M20	20	45, +5+5...			
		20 x 2,0 = 7,00 cm ²	G 3/8"	16,7	20		80, 110, 140, 200, ...	13 = 1,3 cm ²
		8 x 5,0 = 7,00 cm ²						

Filterdüsen

Filter-Nozzles

Crépines à filtre

Toberas filtrantes

Typ DSP

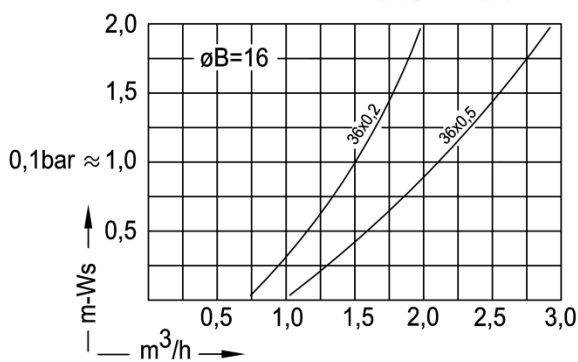
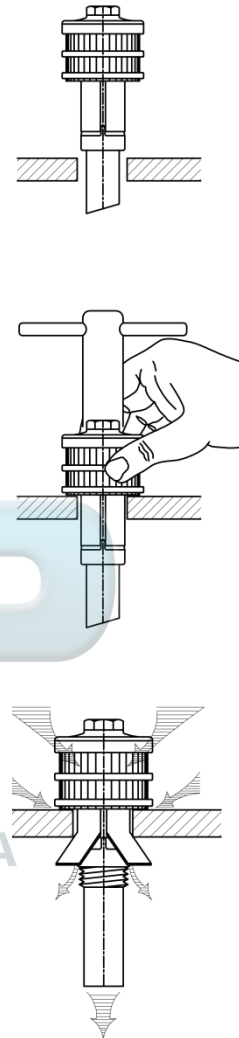
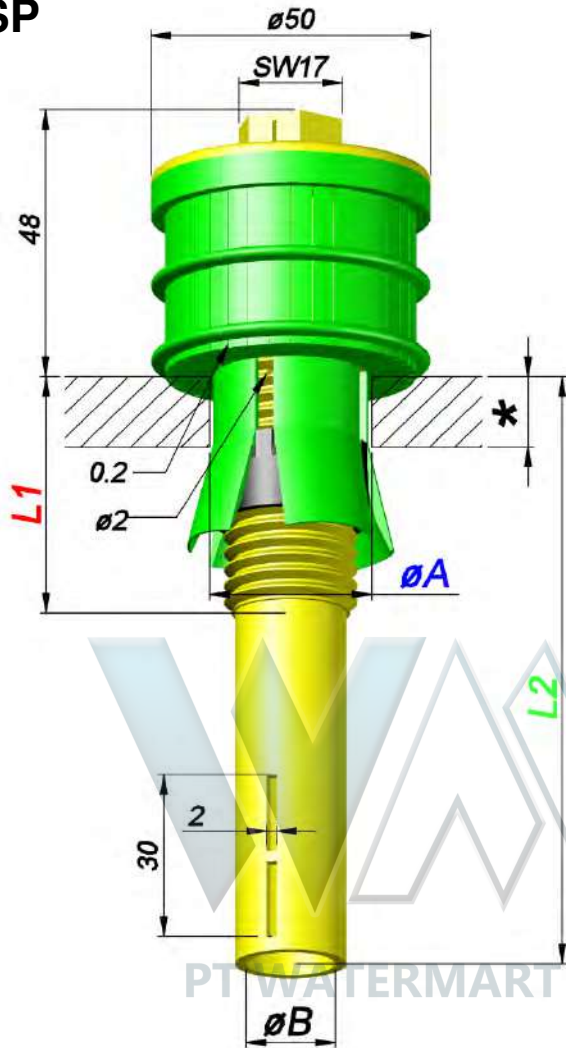

Bestellung Ordering Commande Encargo	Typ Type Type Tipa	Schlitze Slots Fentes Ranuras	*	L1	Schaft Shaft Longueur de tige Tija	L2	øA	øB
	DSP	36 x 0,2 = 1,37 cm²	8 - 28	50	80, 110, 140, 200, 250		28-29,5; 29,5-31,5; 31,5-33;	16 = 2,0 cm²
		36 x 0,3 = 2,05 cm²	25 - 45	73	110, 140, 200, 250		33-34,5; 34,5-36;	
		36 x 0,5 = 3,42 cm²						
		36 x 1,0 = 6,84 cm²						
		36 x 0,2 = 1,37 cm²	25- 45	73	100, 110, 140, max. 200		25-27,5	13 = 1,3 cm²
		36 x 0,5 = 3,42 cm²					26 - 28	

Typ C1

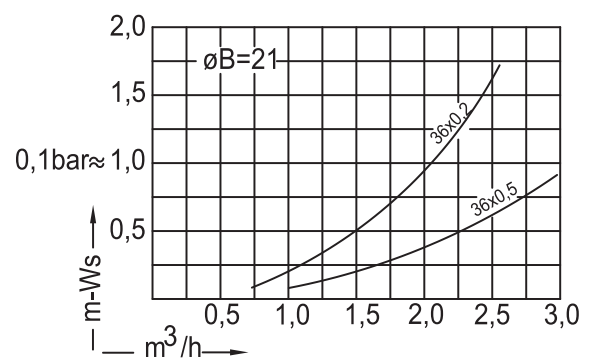
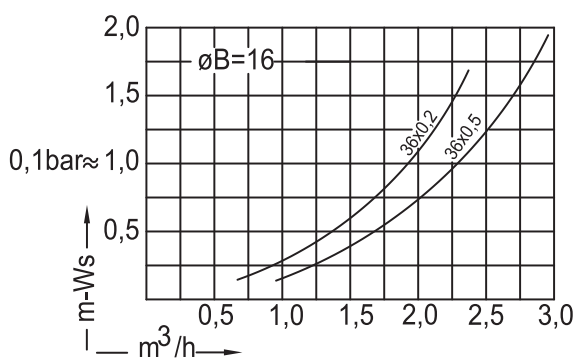
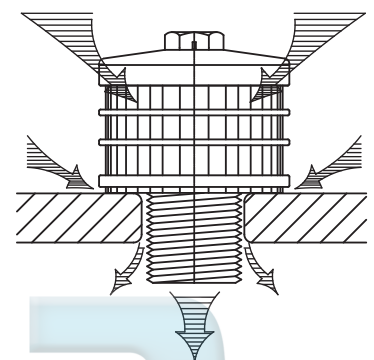
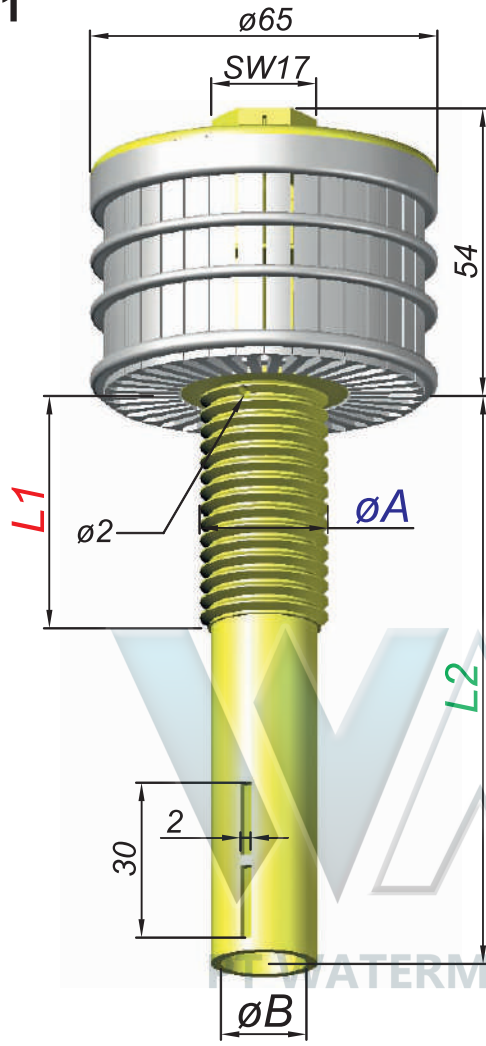

Bestellung Ordering Commande Encargo	Typ Type Type Tipa	Schlitze Slots Fentes Ranuras	Gewinde Thread Filetage Rosca	ϕA	Gewindelänge Thread length Longueur de filetage Largura de la rosca	Schaft Shaft Longueur de tige Tija	ϕB
					$L1$		
✉	C1	36 x 0,2 = 1,95 cm ²	1¼"WW	32	25, 30, 45	80, 110, 140, 200, 250, 300, 350, ...	21 = 3,4 cm ²
		36 x 0,3 = 2,90 cm ²	M30	30 x 3.5	30		
		36 x 0,5 = 4,90 cm ²	G 3/4"	26,5	20, 45, +5+5...		
		36 x 0,7 = 6,80 cm ²	1"WW	25,4	20, 45, +5+5...		
		36 x 1,0 = 9,80 cm ²	M24	24	20, 45, +5+5...	80, 110, 140, 200, 250, 300, 350, ...	16 = 2,0 cm ²

Typ C2

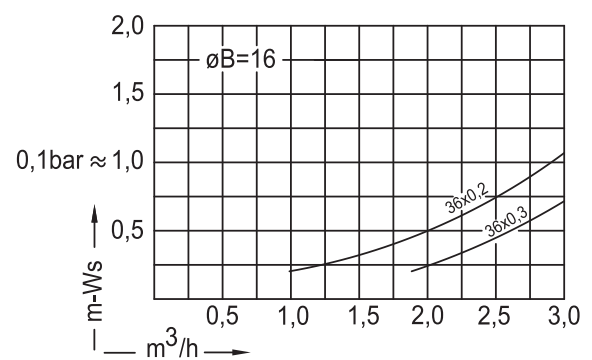
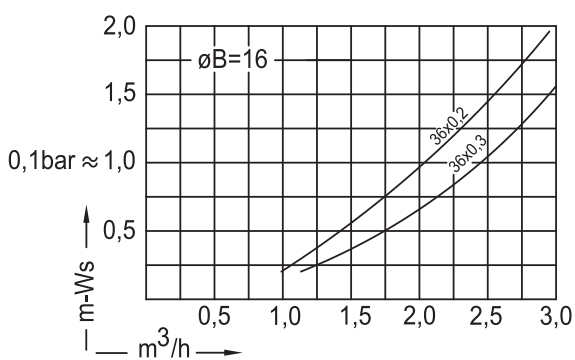
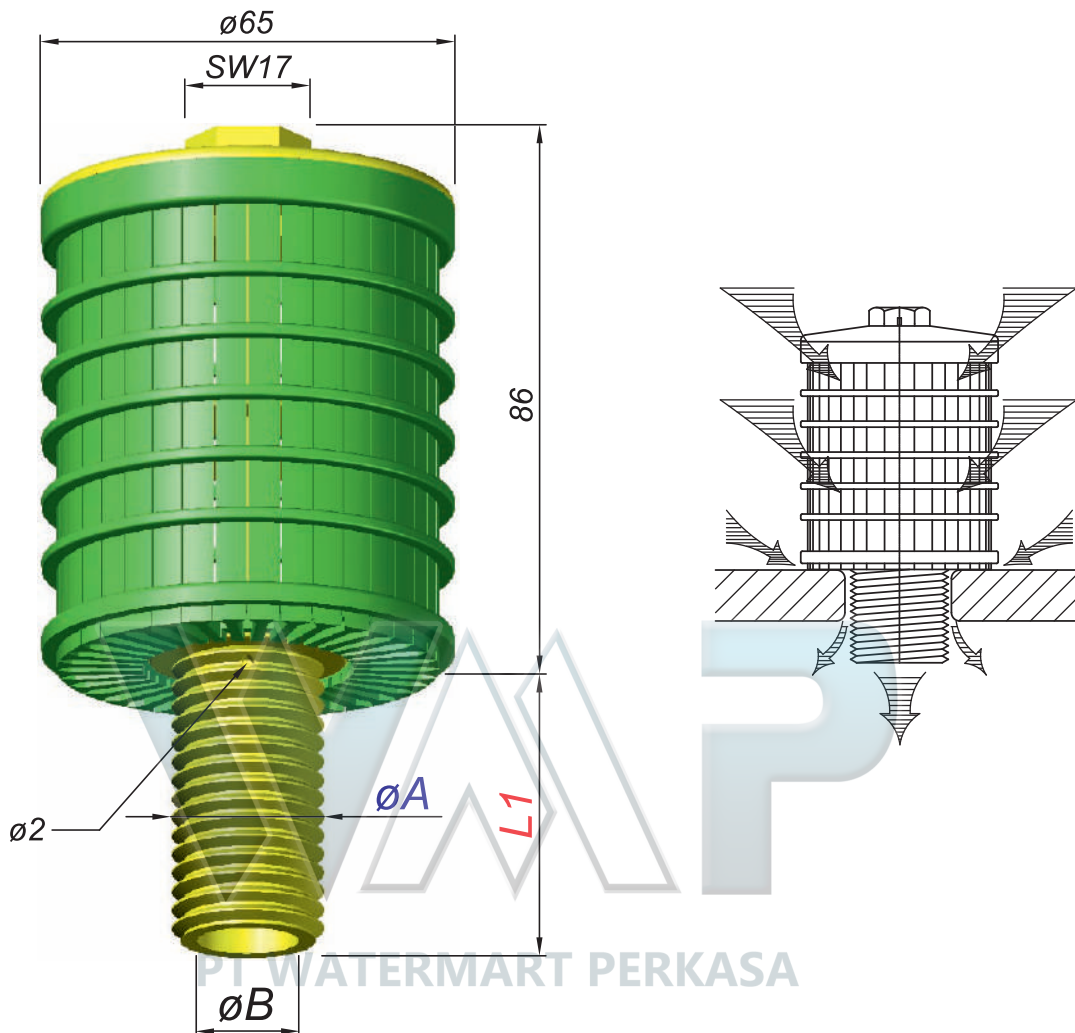

Bestellung Ordering Commande Encargo	Typ Type Type Tipa	Schlitze Slots Fentes Ranuras	Gewinde Thread Filetage Rosca	øA	Gewindelänge Thread length Longueur de filetage Largura de la rosca	L1	øB
	C2	36 x 0,2 = 3,70 cm ² 36 x 0,3 = 5,50 cm ² 36 x 0,5 = 9,61 cm ²	1¼"WW	32	25, 30, 45		21 = 3,4 cm ²
			M30 x 3.5	30	30		
			G 3/4"	26,5	20, 45, +5+5...		16 = 2,0 cm ²
			1"WW	25,4	45		
			M24	24	20, 45, +5+5...		

Filterdüsen

Filter-Nozzles

Crépines à filtre

Toberas filtrantes

Typ K2

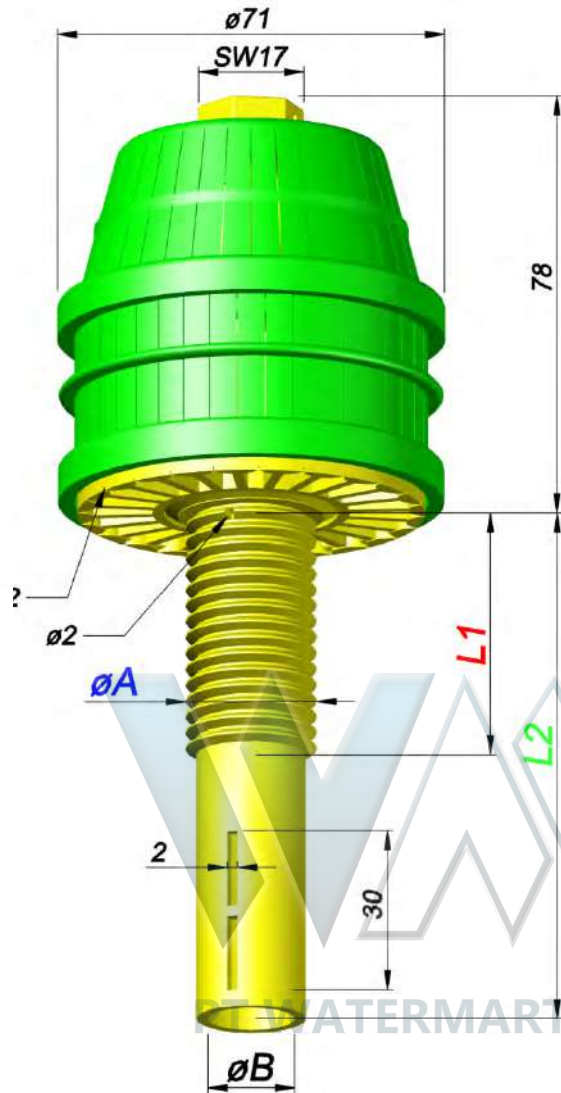

Typ K2

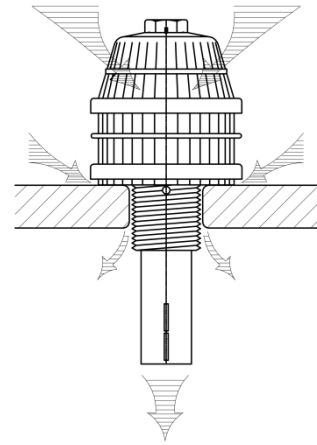

Typ KR2

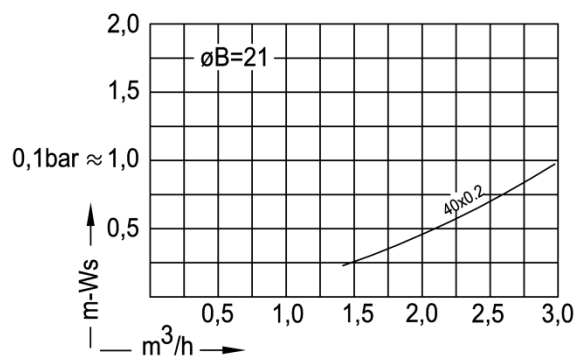
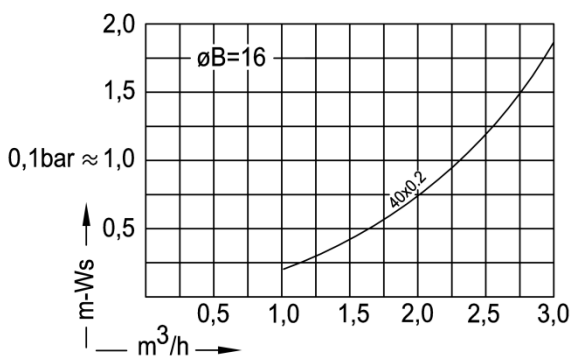
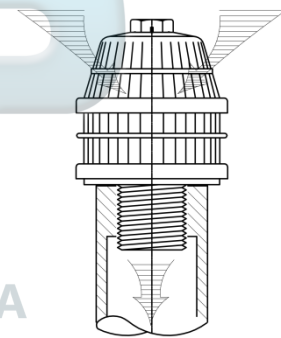

Bestellung Ordering Commande Encargo	Typ Type Type Tipa	Schlitze Slots Fentes Ranuras	Gewinde Thread Filetage Rosca	øA	Gewindelänge Thread length Longueur de filetage Largura de la rosca	Schaft Shaft Longueur de tige Tija	øB
✉	K2	40 x 0,2 = 3,63 cm ² 40 x 0,35 = 6,35 cm ²	1 1/4"WW	32	25, 45	80, 110, 140, ...	21 = 3,4 cm ²
			M30 x 3.5	30	30		
			G 3/4"	26,5	25, 45	80, 110, 140, ...	16 = 2,0 cm ²
			M24	24	25, 45		
	KR2						

Filterdüsen

Filter-Nozzles

Crépines à filtre

Toberas filtrantes

Typ P

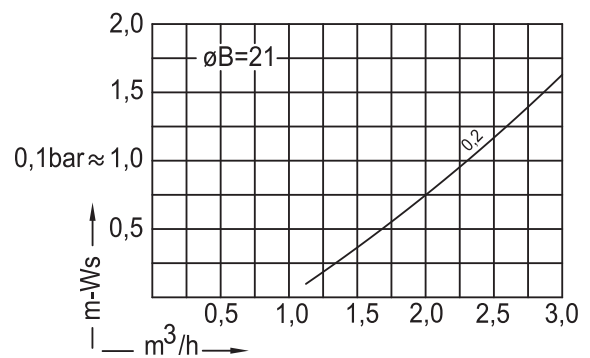
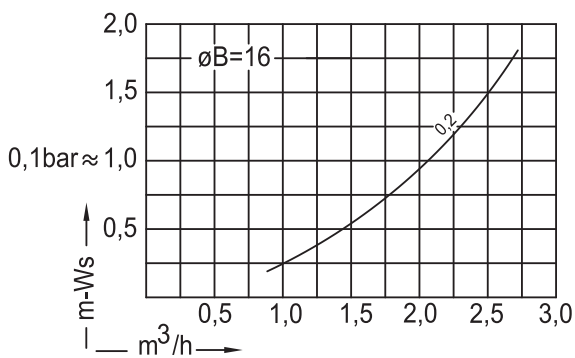
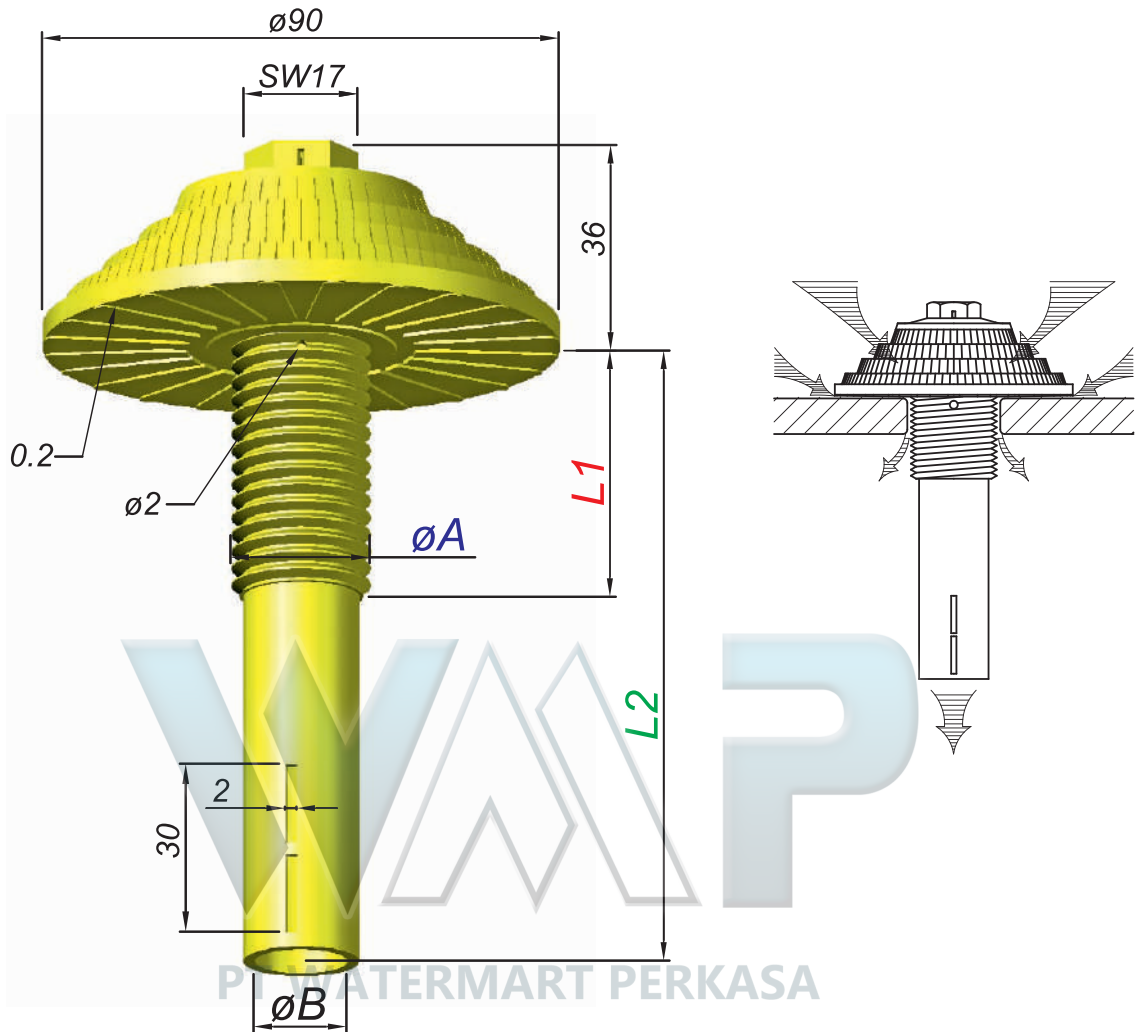

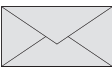
Bestellung Ordering Commande Encargo	Typ Type Type Tija	Schlitze Slots Fentes Ranuras	Gewinde Thread Filetage Rosca	$\varnothing A$	Gewindelänge Thread length Longueur de filetage Largura de la rosca	Schaft Shaft Longueur de tige Tija	$\varnothing B$
	P	0,2 = 3,0 cm ²	1¼"WW	32	25, 45, +5 +5 ...	80, 110, 140	21 = 3,4 cm ²
			G 3/4"	26,5	20, 45, +5 +5 ...	80, 110, 140	16 = 2,0 cm ²
			1"WW	25,4	20, 45		
			M24	24	20, 45, +5 +5 ...		

**Filterdüsen
mit beweglichen
Lamellen**

**Filter-Nozzles
Rotating
Filter-Disc**

**Crepine a Filtre
a Lamelles
Rotatives**

**Toberas filtrantes
de lamelas
Rotativas**

Typ LB

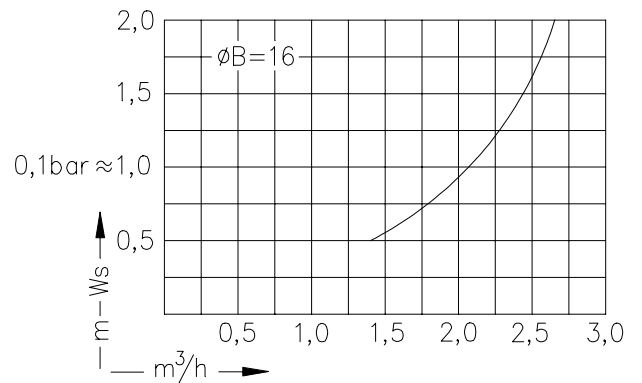
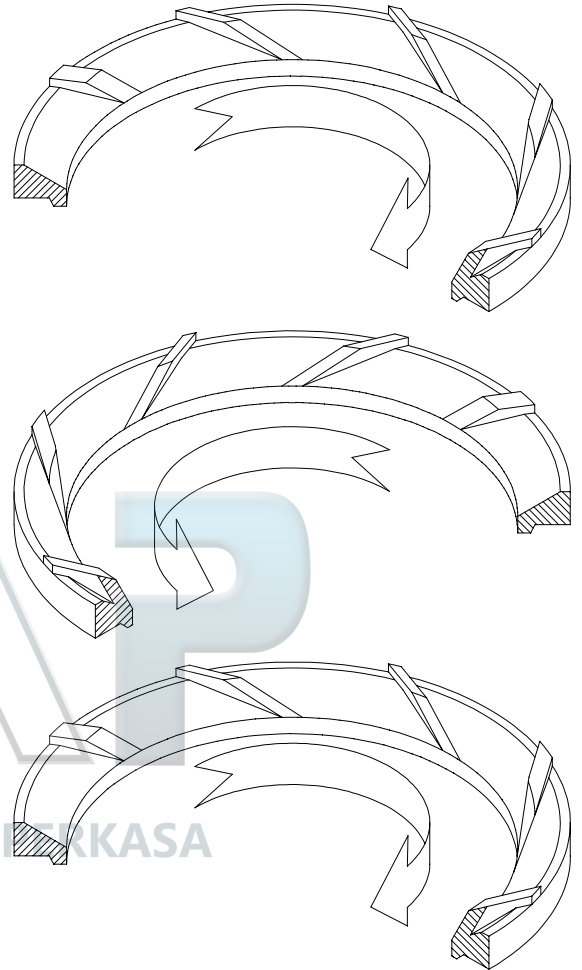
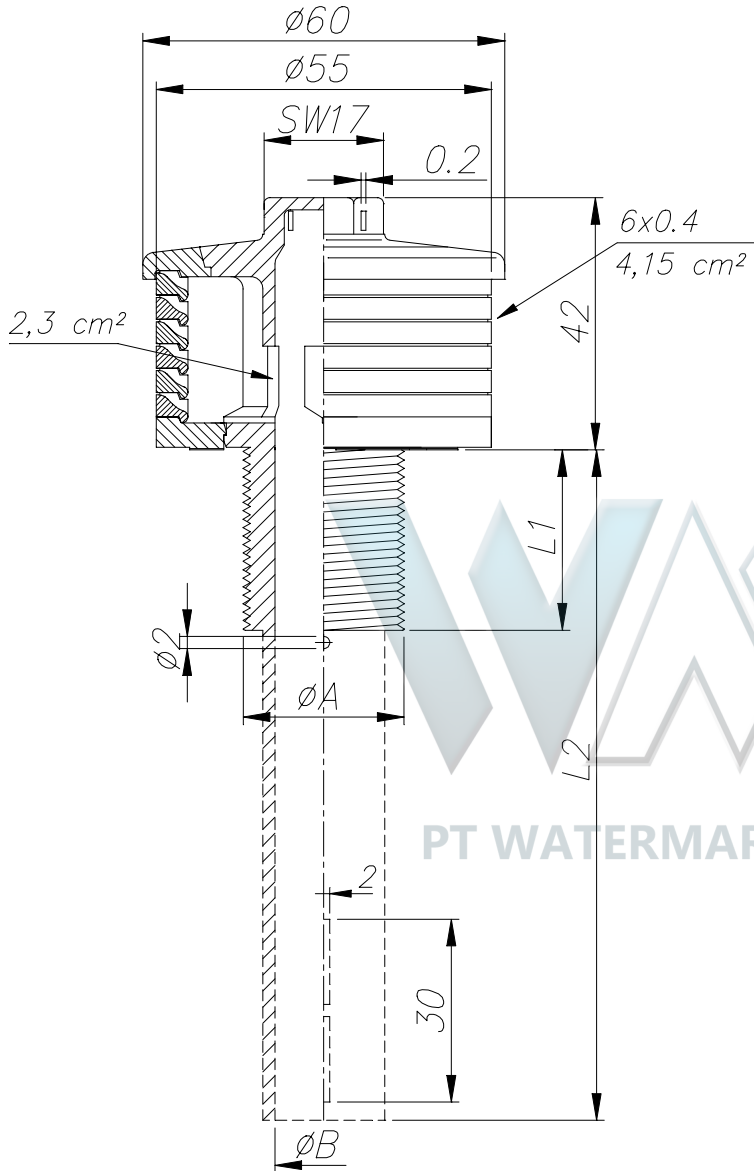

Bestellung Ordering Commande Encargo	Typ Type Type Tipa	Schlitze Slots Fentes Ranuras	*	Gewinde Thread Filetage Rosca	øA	Gewindelänge Thread length Longueur de filetage Largura de la rosca	L1	Schaft Shaft Longueur de tige Tija	L2	øB
	LB	6 x 0,4 = 4,15 cm ² 4 x 2,5 = 14,60 cm ²		1 1/4"WW	32	20, 30, 45, +5 +5 ...	L1, 80, 110, 140, 200, ... 417 ...	16 = 2,0 cm ²		
				1"WW	25,4	20, 45, +5 +5 ...	L1, 80, 110, 140, 200, ... 417 ...	16 = 2,0 cm ²		
				G 3/4"	26,5	20, 30, 45, +5 +5 ...	L1, 80, 110, 140, 200, ... 417 ...	16 = 2,0 cm ²		
				M24	24	25, 45, +5 +5 ...	L1, 80, 110, 140, 200, ... 417 ...	16 = 2,0 cm ²		
				M22x1,5	22	45, +5 +5 ...	L1, 80, 110, 140, 200, ... 417 ...	16 = 2,0 cm ²		

**Filterdüsen
mit beweglichen
Lamellen**

**Filter-Nozzles
Rotating
Filter-Disc**

**Crepine a Filtre
a Lamelles
Rotatives**

**Toberas filtrantes
de lamelas
Rotativas**

Typ LB2

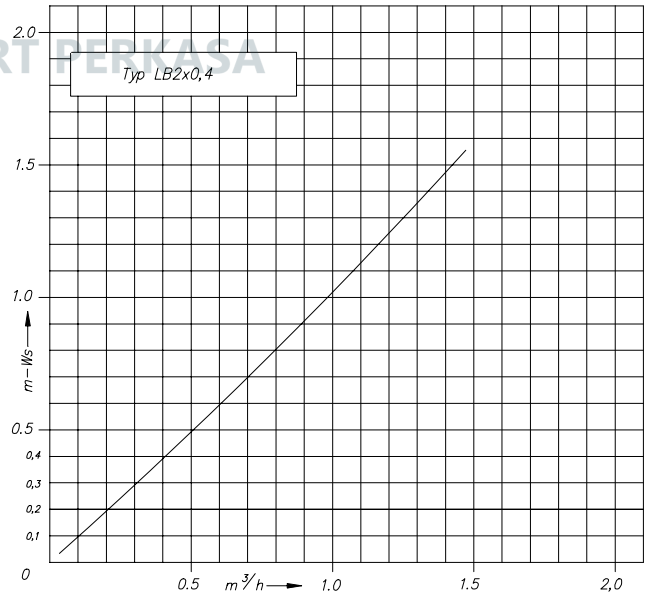
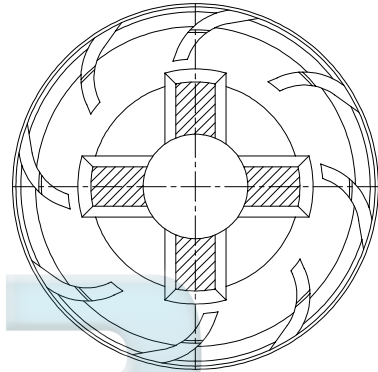
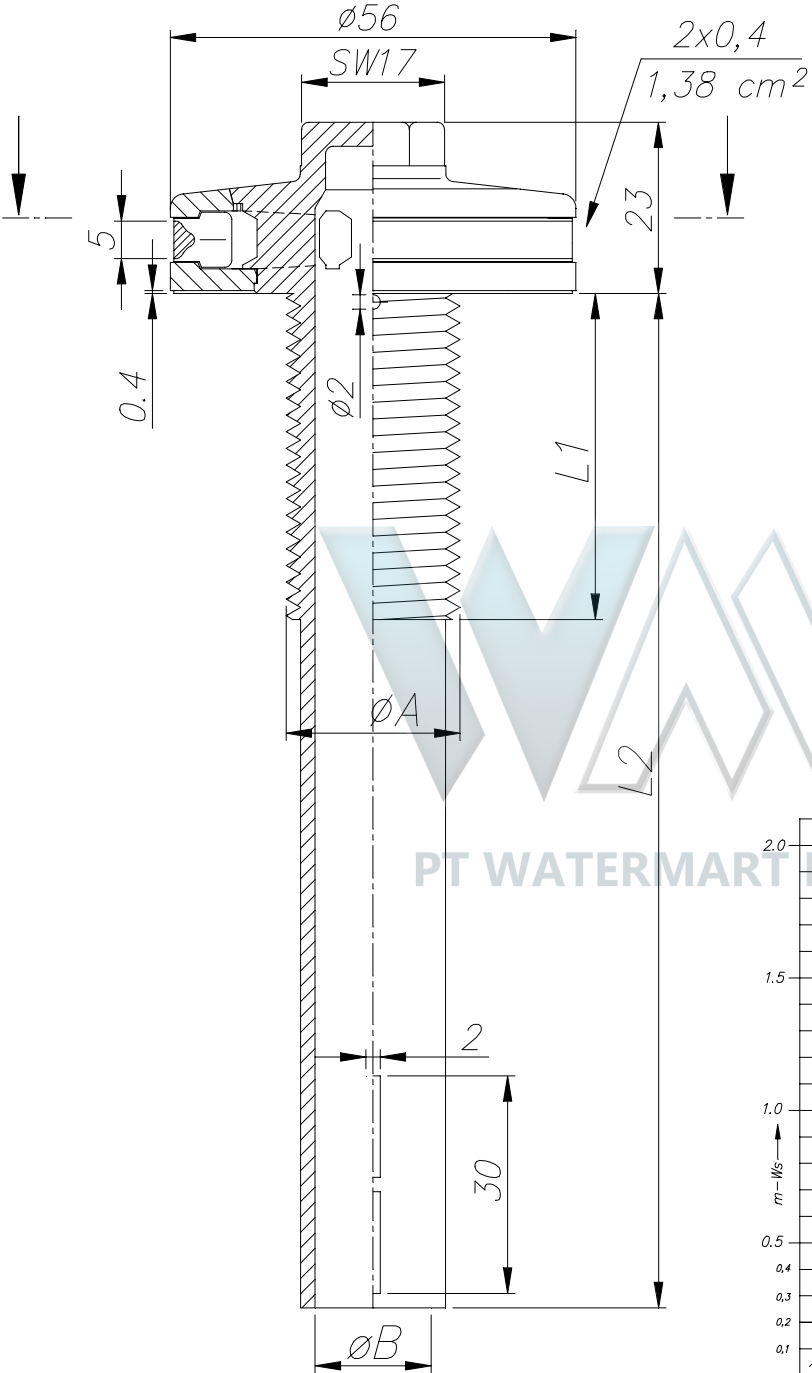

PT WATERMART PERKASA

Bestellung Ordering Commande Encargo	Typ Type Type Tipa	Schlitze Slots Fentes Ranuras	Gewinde Thread Filetage Rosca	ϕA	Gewindelänge Thread length Longueur de filetage Largura de la rosca	L1	Schaft Shaft Longueur de tige Tija	L2	ϕB
	LB2	2 x 0,4 = 1,38 cm²	1 1/4"WW	32	20, 30, 45, +5 +5 ...	L1, 80, 110, 140, 200	16 = 2,0 cm²		
			1"WW	25,4	20, 45, +5 +5 ...	L1, 80, 110, 140, 200	16 = 2,0 cm²		
			G 3/4"	26,5	20, 30, 45, +5 +5 ...	L1, 80, 110, 140, 200	16 = 2,0 cm²		
			M24	24	25, 45, +5 +5 ...	L1, 80, 110, 140, 200	16 = 2,0 cm²		
			M22x1,5	22	45, +5 +5 ...	L1, 80, 110, 140, 200	16 = 2,0 cm²		

Typ S1

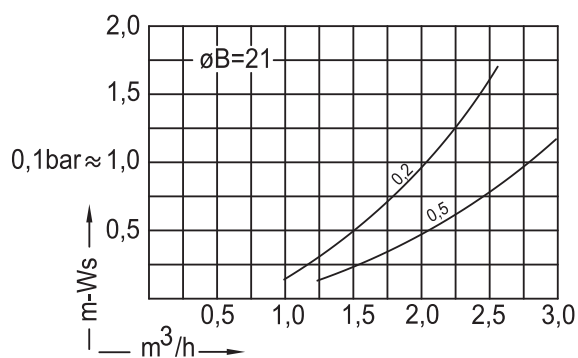
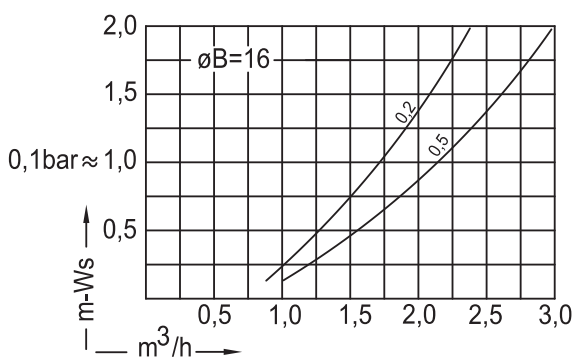
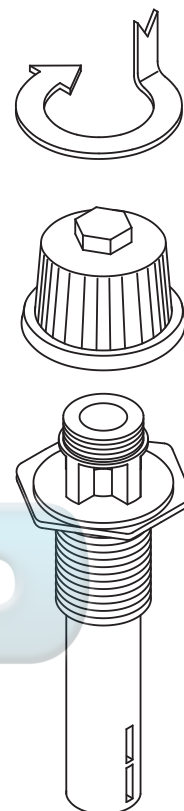
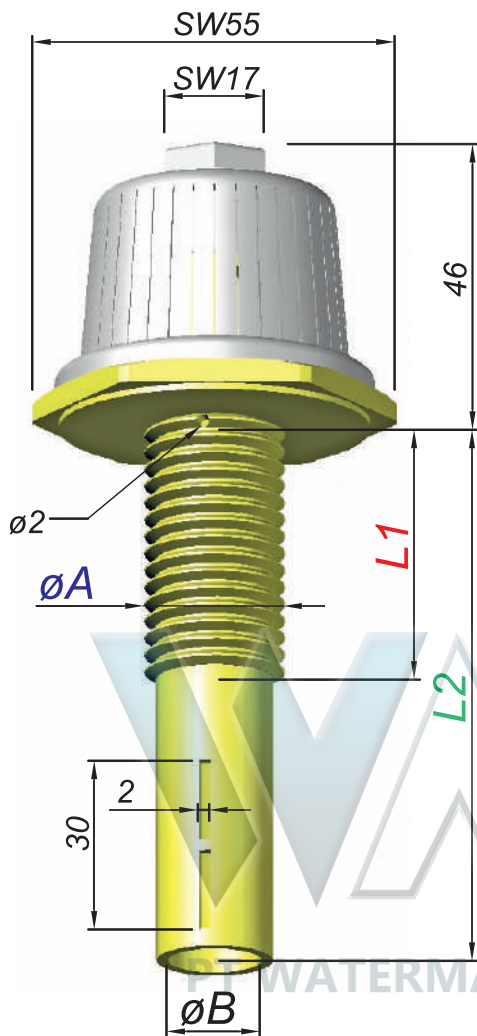

Bestellung Ordering Commande Encargo	Typ Type Type Tipa	Schlitze Slots Fentes Ranuras	Gewinde Thread Filetage Rosca	øA	Gewindelänge Thread length Longueur de filetage Largura de la rosca	Schaft Shaft Longueur de tige Tija	øB
	S1	36 x 0,2 = 1,72 cm ² 36 x 0,35 = 2,65 cm ² 30 x 0,5 = 3,78 cm ² 18 x 1,0 = 4,64 cm ² 18 x 2,0 = 9,29 cm ²	G 1"	33,25	20	80, 110, 140, 200, 250, 300, 350, ...	21 = 3,4 cm ²
			1¼"WW	32	25, 30, 45		
			M30	30	30		
			G 3/4"	26,5	20, 45, 50, +5 +5...	80, 110, 140, 200, 250, 300, 350, ...	16 = 2,0 cm ²
			1"WW	25,4	45		
			M24	24	20, 45, 50, +5 +5...		

Typ S2

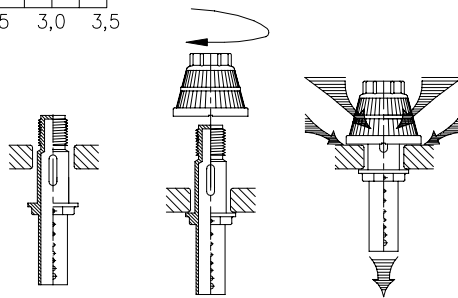
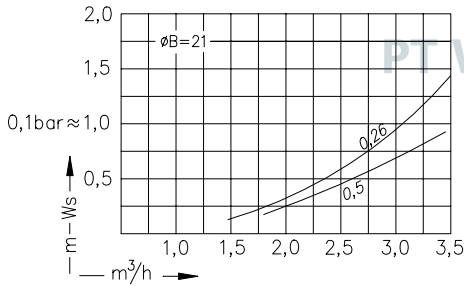
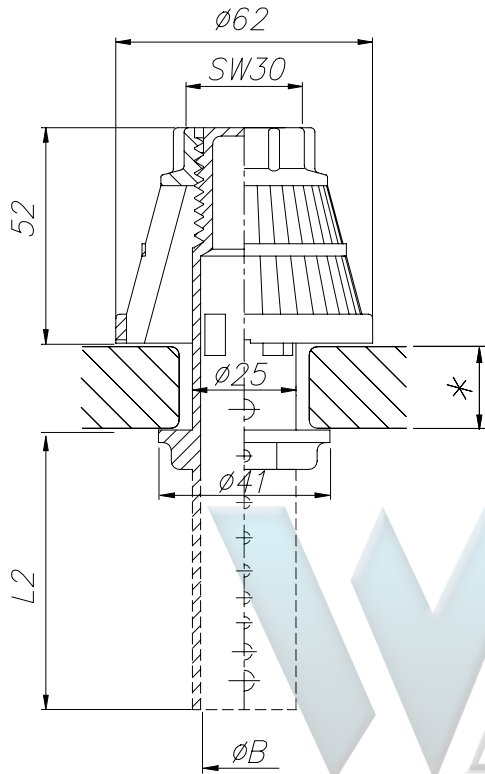

Typ S3

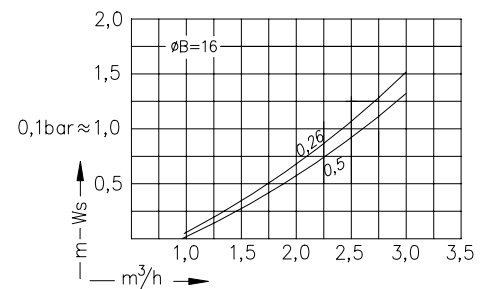
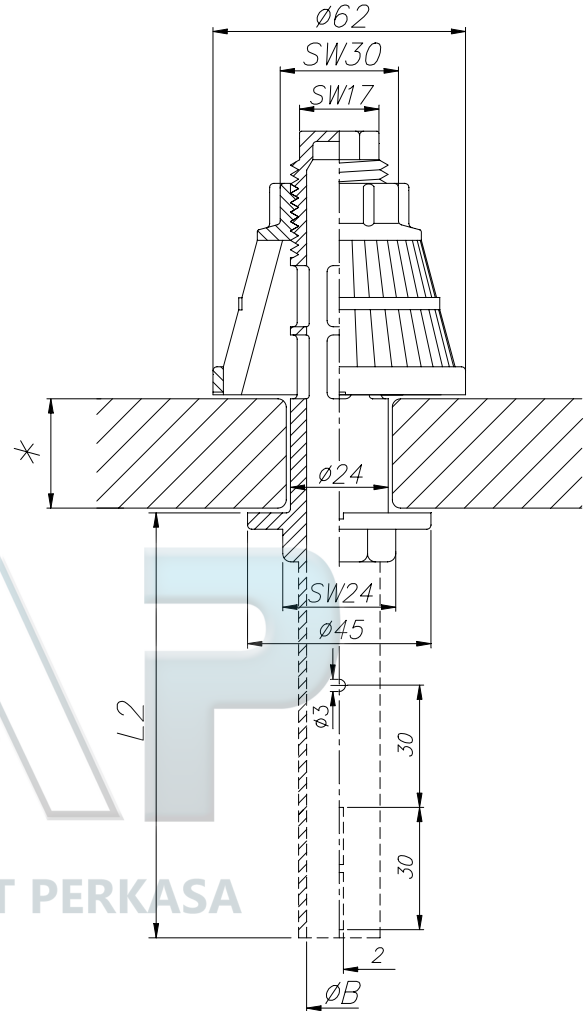

Bestellung Ordering Commande Encargo	Typ Type Type Tipa	Schlitz Slots Fentes Ranuras	*	Schaft Shaft Longueur de tige Tija	L2	øB
✉	S2	40 x 0,26 = 3,04 cm ²	6 - 22	67,5		21 = 3,4 cm ²
		40 x 0,5 = 5,84 cm ²	18 - 34	67,5		21 = 3,4 cm ²
		40 x 0,7 = 8,18 cm ²	1 - 18	0		21 = 3,4 cm ²
			18 - 34	0		21 = 3,4 cm ²
	S3	40 x 0,26 = 3,04 cm ²	6 - 8	80, 102, 140 ...		16 = 2,0 cm ²
40 x 0,5 = 5,84 cm ²		8 - 12	16 = 2,0 cm ²			
40 x 0,7 = 8,18 cm ²		12 - 20	16 = 2,0 cm ²			
		20 - 30	16 = 2,0 cm ²			
		30 - 40	16 = 2,0 cm ²			

Filterdüsen

Filter-Nozzles

Crépines à filtre

Toberas filtrantes

Typ S3

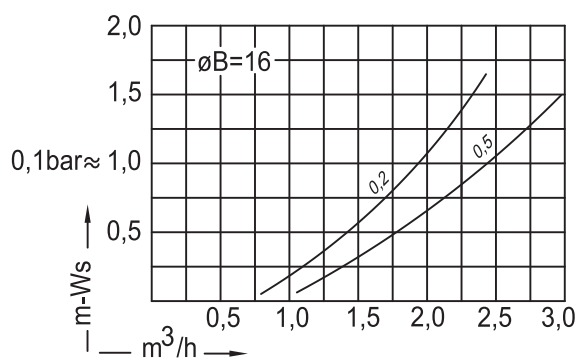
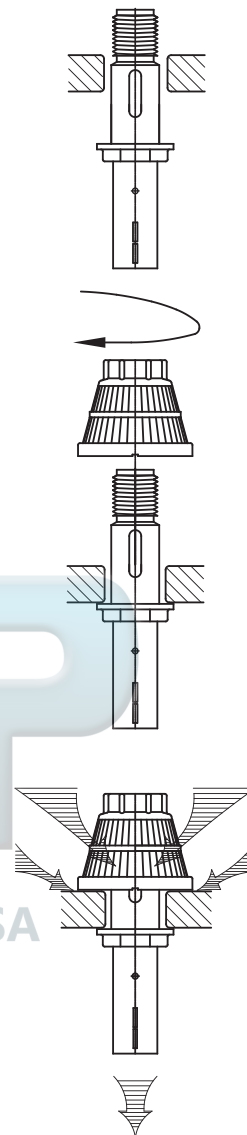
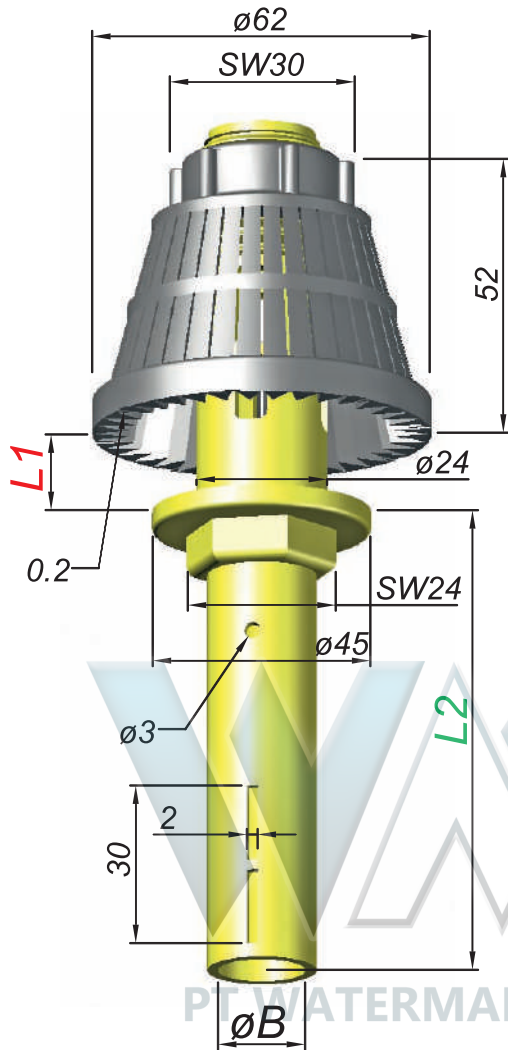

Bestellung Ordering Commande Encargo	Typ Type Type Tipa	Schlitz Slots Fentes Ranuras	Bodenstärke plate thickness Epaisseur du plancher Espesor placa	Schaft Shaft Longueur de tige Tija	ϕB
	S3	40 x 0,2 = 3,04 cm ² 40 x 0,5 = 5,84 cm ² 40 x 0,7 = 8,18 cm ²	6 - 12	80, 110, 140, ...	16 = 2,0 cm ²
			12 - 20		
			20 - 30		
			30 - 40		

Filterdüsen

Filter-Nozzle

Crepines a filtre

Toberas filtrantes

Typ S3G

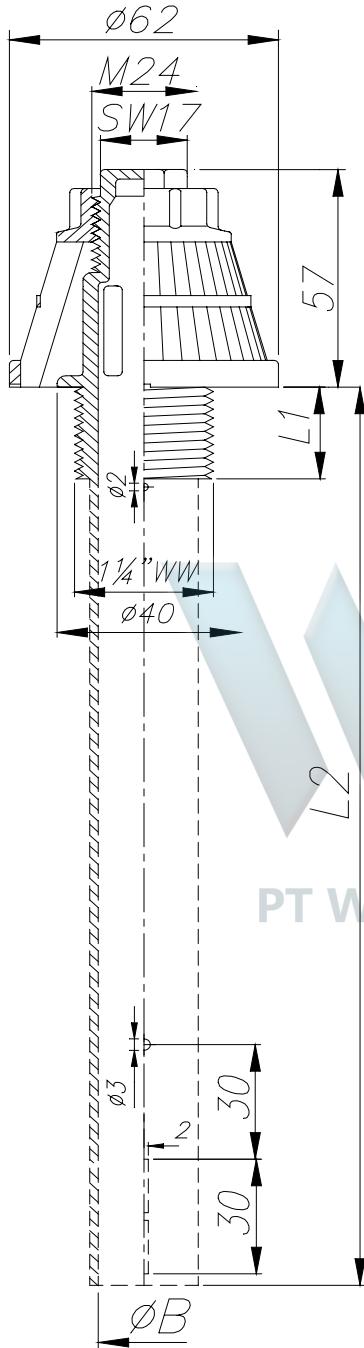

Typ GR

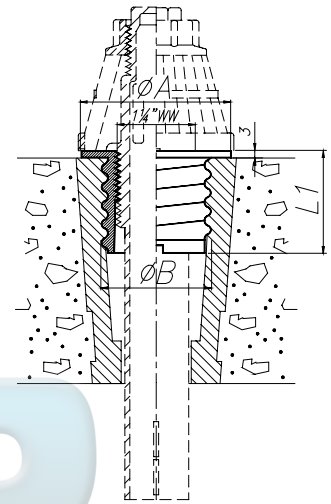

PT WATERMART PERKASA

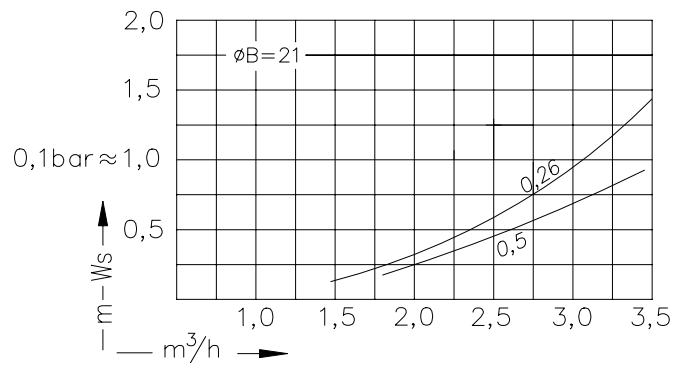

Bestellung Ordering Commande Encargo	Typ Type Type Tipa	Schlitze Slots Fentes Ranuras	Gewinde Thread Filetage Rosca	ØA	Gewindelänge Thread length Longueur de filetage Largura de la rosca	Schaft Shaft Longueur de tige Tija	ØB
✉	S3G	40 x 0,26 = 3,04 cm²	1 1/4" WW	32	20, 30, 45, +5 +5 ...	L1, 80, 110, 140, 200, 250, ... 395...	21 = 3,4 cm²
		40 x 0,5 = 5,84 cm²	G 3/4"	26,5	20, 45, 50, +5 +5 ...	L1, 80, 110, 140, 200, 250, ...	16 = 2,0 cm²
		40 x 0,7 = 8,18 cm²	M24	24	20, 45, 50, +5 +5 ...	L1, 80, 110, 140, 200, 250, ...	16 = 2,0 cm²
		Typ Type Type Tipa	ØA	L1	Gewinde Thread Filetage Rosca	ØB	
	GR						
		60	37	RD 44			

Filterdüsen

Filter-Nozzle

Crepines a filtre

Toberas filtrantes

Typ G

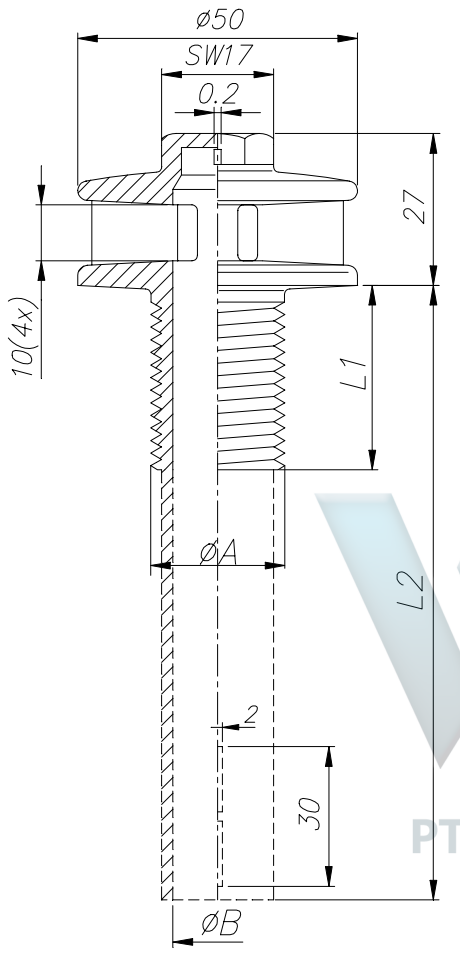

Typ RSP

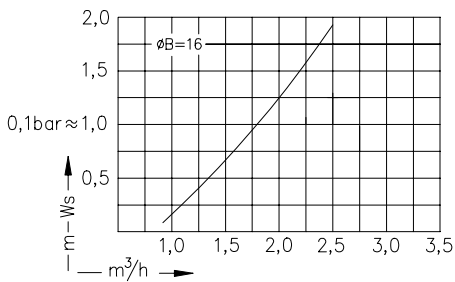
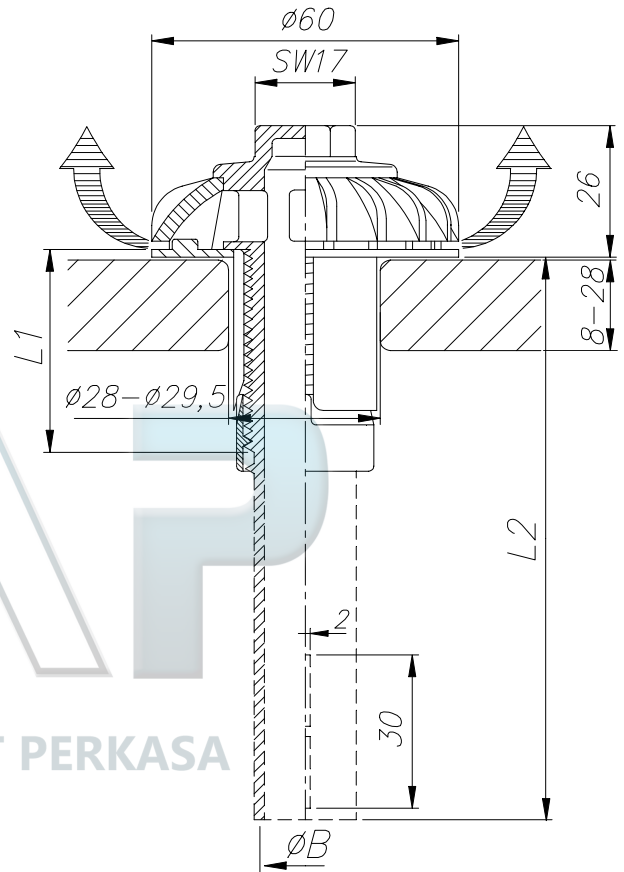

Bestellung Ordering Commande Encargo	Typ Type Type Tipa	Schlitze Slots Fentes Ranuras	Gewinde Thread Filetage Rosca	ØA	Gewindelänge Thread lenght Longueur de filetage L1 Largura de la rosca	Schaft Shaft Longueur de tige Tija L2	ØB
✉	G	5 = 2,0 cm ²	1 ¼"WW	32	20, 30, 45, +5 +5 ...	L1, 80, 110, 140, 200, 250, ... 417...	21 = 3,4 cm ²
			G 3/4"	26,5	20, 30, 45, +5 +5 ...	L1, 80, 110, 140, 200, 250, ... 417...	16 = 2,0 cm ²
			M24	24	25, 45, +5 +5...	L1, 80, 110, 140, 200, 250, ... 417...	16 = 2,0 cm ²
	RSP 8-28	1,6 = 2,67 cm ² 5,6 = 9,35 cm ²			50	L1, 80, 110, 140, 200	16 = 2,0 cm ²

PT WATERMART PERKASA

Filterdüsen

Filter-Nozzles

Crépines à filtre

Toberas filtrantes

Typ G

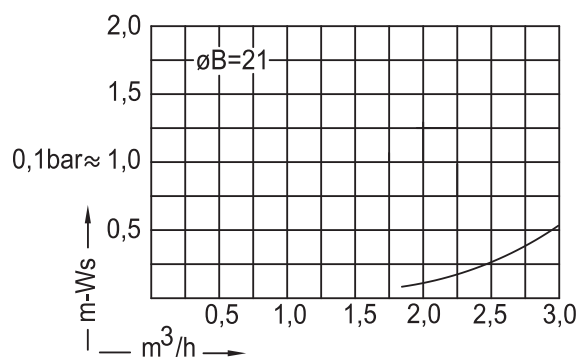
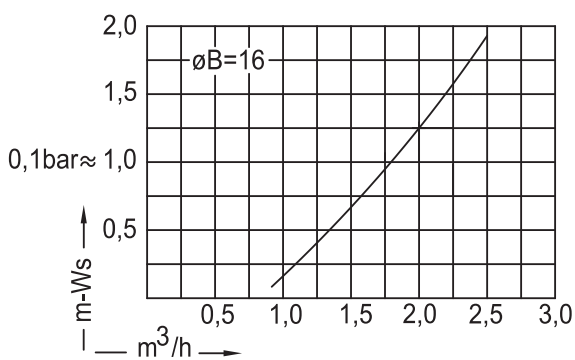
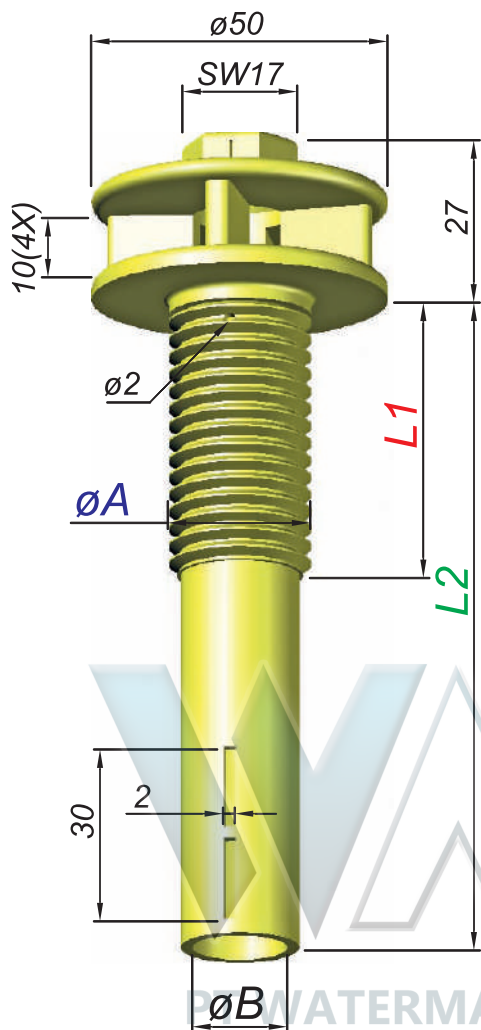

Bestellung Ordering Commande Encargo	Typ Type Type Tipa	Schlitze Slots Fentes Ranuras	Gewinde Thread Filetage Rosca	$\varnothing A$	Gewindelänge Thread length Longueur de filetage Largura de la rosca	Schaft Shaft Longueur de tige Tija	$\varnothing B$
					L1	L2	
	G	5 = 2,0 cm ²	G 1"	33,25	20	80, 110, 140, 200, 250, 300, 350, ...	21 = 3,4 cm ²
			1½" WW	32	20, 30, 45, +5+5...		
			M30 x 3.5	30	30		
			G 3/4"	26,5	20, 30, 45, +5+5...	80, 110, 140, 200, 250, 300, 350, ...	16 = 2,0 cm ²
			1" WW	25,4	20, 45, +5+5...		
			M24	24	25, 45, +5+5...		
			M22 x 1,5	22	45, +5+5...		

Typ G2

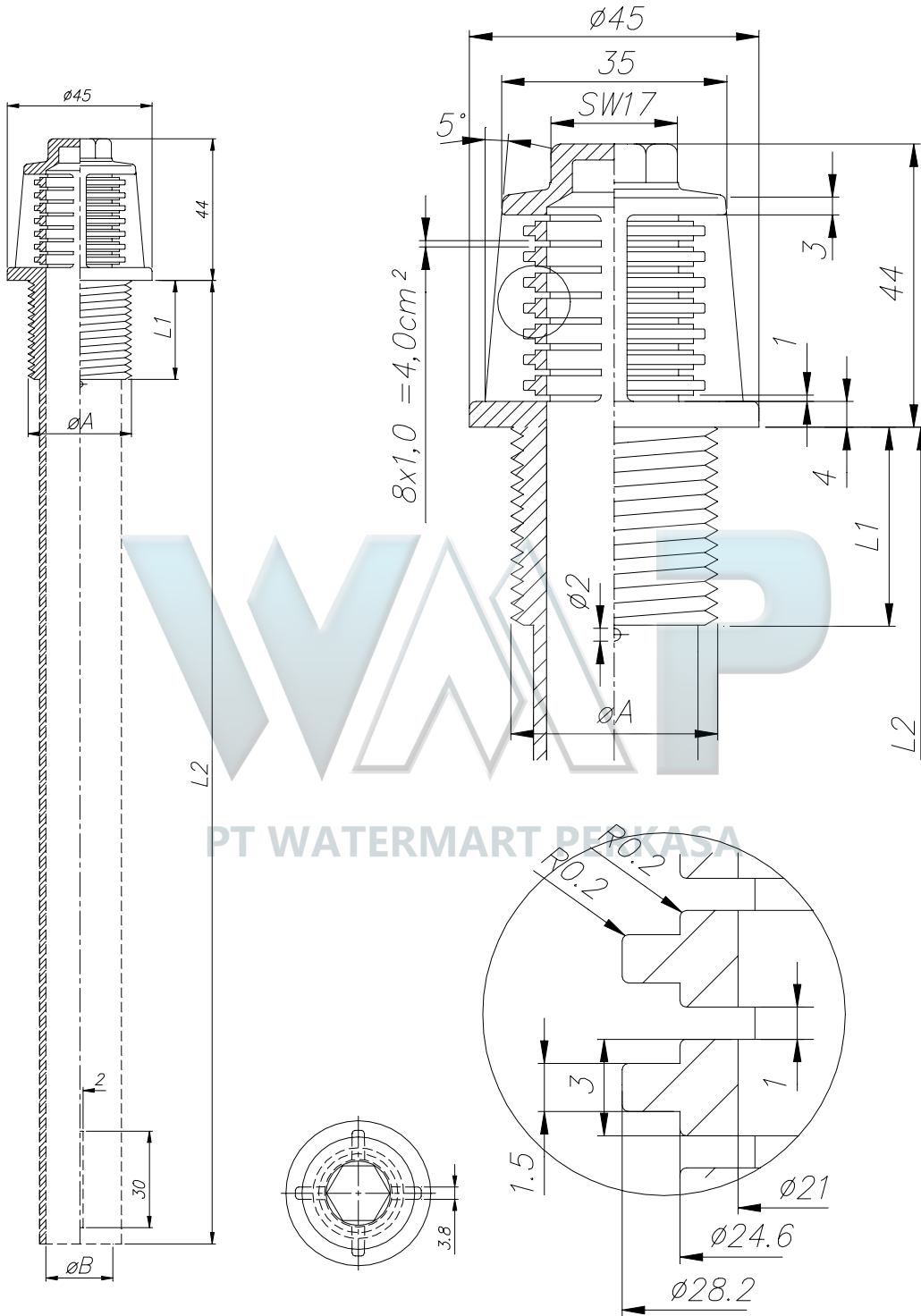

Bestellung Ordering Commande Encargo	Typ Type Type Tipa	Schlitze Slots Fentes Ranuras	*	Gewinde Thread Filetage Rosca	øA	Gewindelänge Thread length Longueur de filetage Largura de la rosca	L1	Schaft Shaft Longueur de tige Tija	L2	øB
	G2	8 x 1,0 = 4,0 cm ²		1 1/4" WW	32	20, 30, 45, +5+5...		L1, 80, 100, 140, 200, ...		21 = 3,4 cm ²
				G 1"	33,25	20		L1, 80, 100, 140, 200		21 = 3,4 cm ²
				M30	30	30		L1, 80, 100, 140, 200, ...		21 = 3,4 cm ²

**Filterdüsen
aus Edelstahl**

**VA-Filter-
Nozzles**

**Crepine a Filtr
en VA**

**Toberas filtrantes
de VA**

Typ V10

Material V4A-1.4571 (316ti)

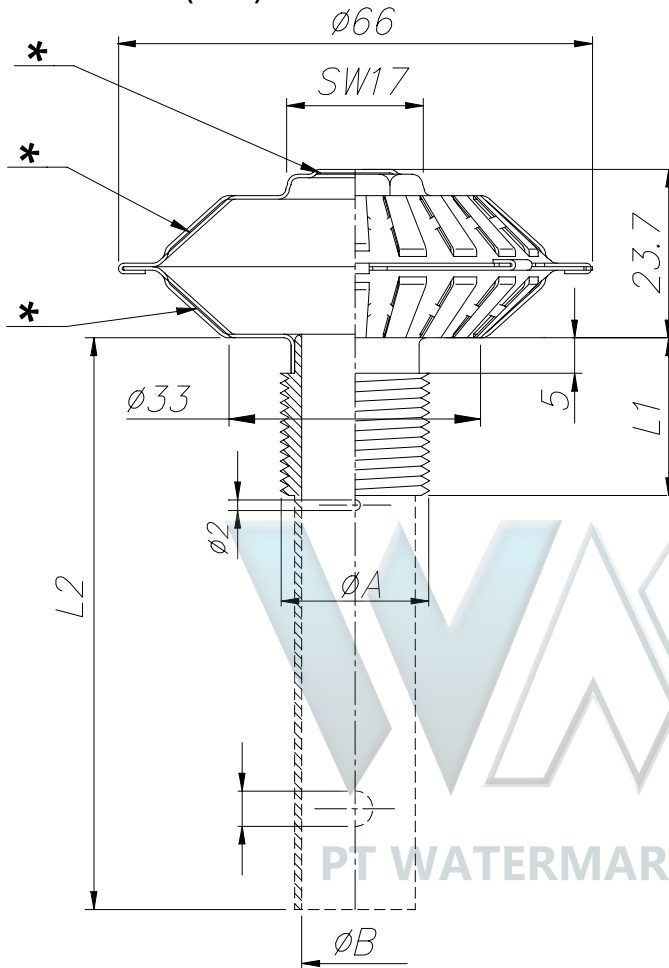

Typ V10-0,2 / V10-0,2- *

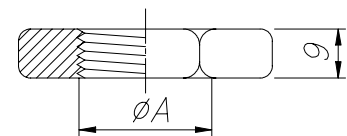
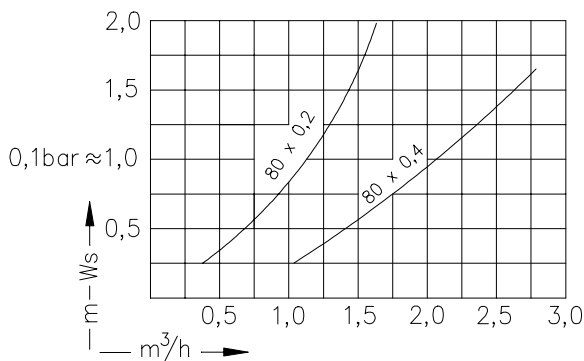
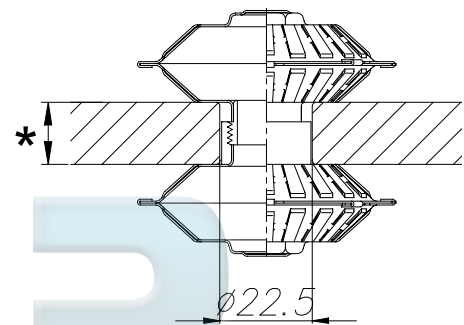

Bestellung Ordering Commande Encargo	Typ Type Type Tipa	Gewinde Thread Filetage Rosca	ϕA
	MUVA	G 1/2" M20x1,5	

Bestellung Ordering Commande Encargo	Typ Type Type Tipa	Schlitze Slots Fentes Ranuras	*	Gewinde Thread Filetage Rosca	ϕA	Gewindelänge Thread length Longueur de filetage Largura de la rosca	L1	Schaft Shaft Longueur de tige Tija	L2	ϕB
	V10	80 x 0,2 = 1,68 cm ² 80 x 0,4 = 3,52 cm ²		G 1/2" M20x1,5	21 20	20, 30 35 +5 +5 ...		L1, 80, 100		16 = 2,0 cm ² 16 = 2,0 cm ²

**Filterdüsen
aus Edelstahl**

**VA-Filter-
Nozzles**

**Crepine a Filtre
en VA**

**Toberas filtrantes
de VA**

Typ V20

Material V4A 1.4571 (316ti)

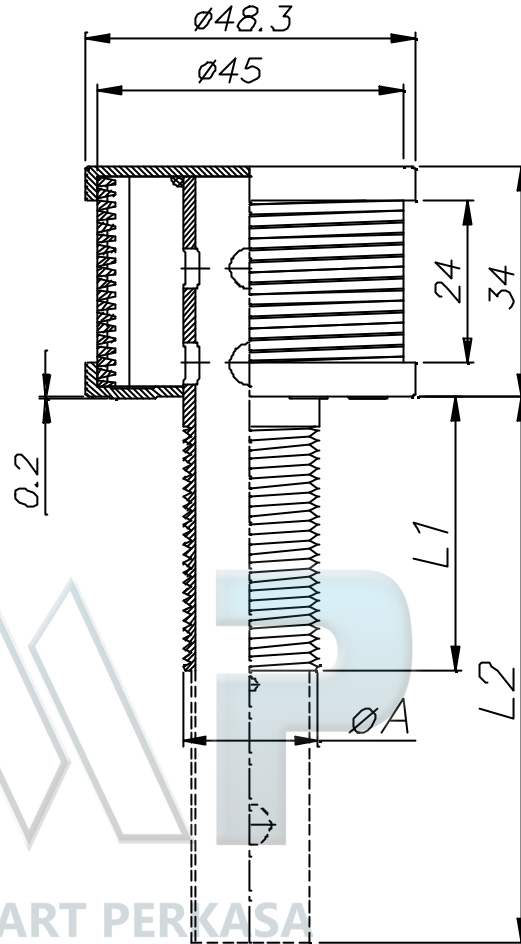
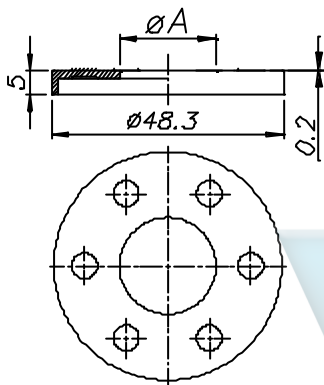

Bestellung Ordering Commande Encargo	Typ Type Type Tipa	$\varnothing A$
	DVA	21 20

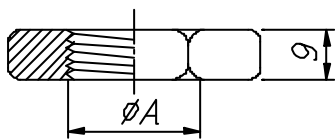

Bestellung Ordering Commande Encargo	Typ Type Type Tipa	Gewinde Thread Filetage Rosca	$\varnothing A$
	MUVA	M20x1,5	

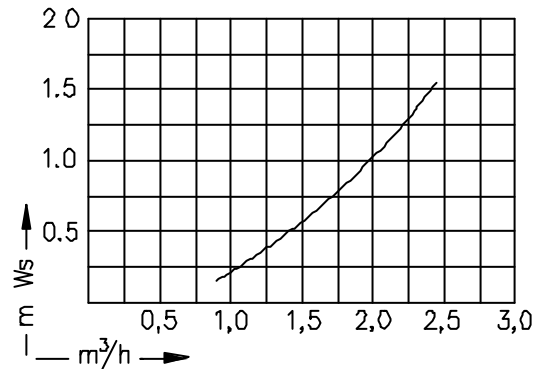

Bestellung Ordering Commande Encargo	Typ Type Type Tipa	Schlitze Slots Fentes Ranuras	Gewinde Thread Filetage Rosca	$\varnothing A$	Gewindelänge Thread length Longueur de filetage Largura de la rosca	L1	Schaft Shaft Longueur de tige Tija	L2
	V20	0,2 = 5,65 cm ²	M20x1,5	20	40, +5, +5...		L1, 80, 100	

Filterdüsenatz

für Zwischenböden

Filter-Nozzles-Set

For intermediate bottoms

Crépines à filtre

Assortiment pour planches intermédiaies

Conjunto de

Toberas para placas intermedias



Filterdüsen

Filter-Nozzle

Crepines a filtre

Toberas filtrantes

Typ MST

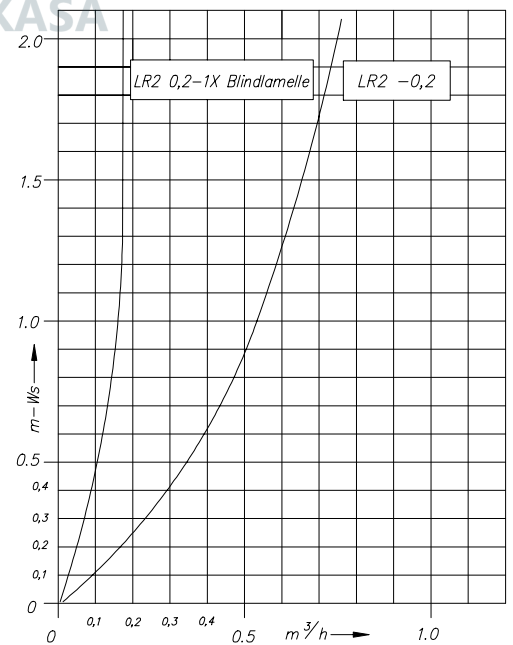
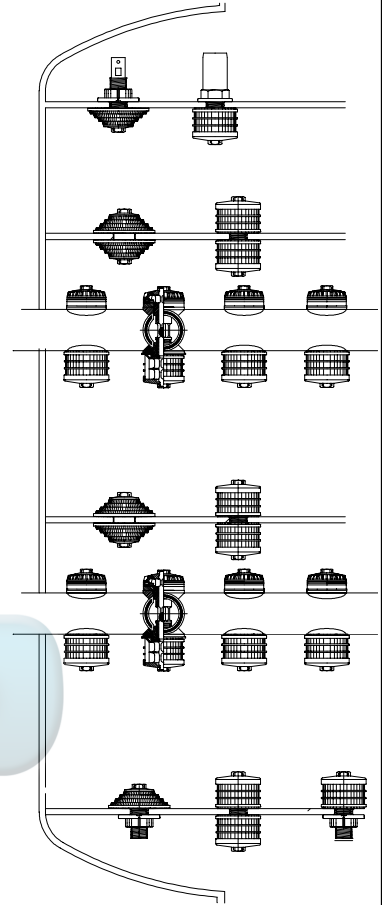
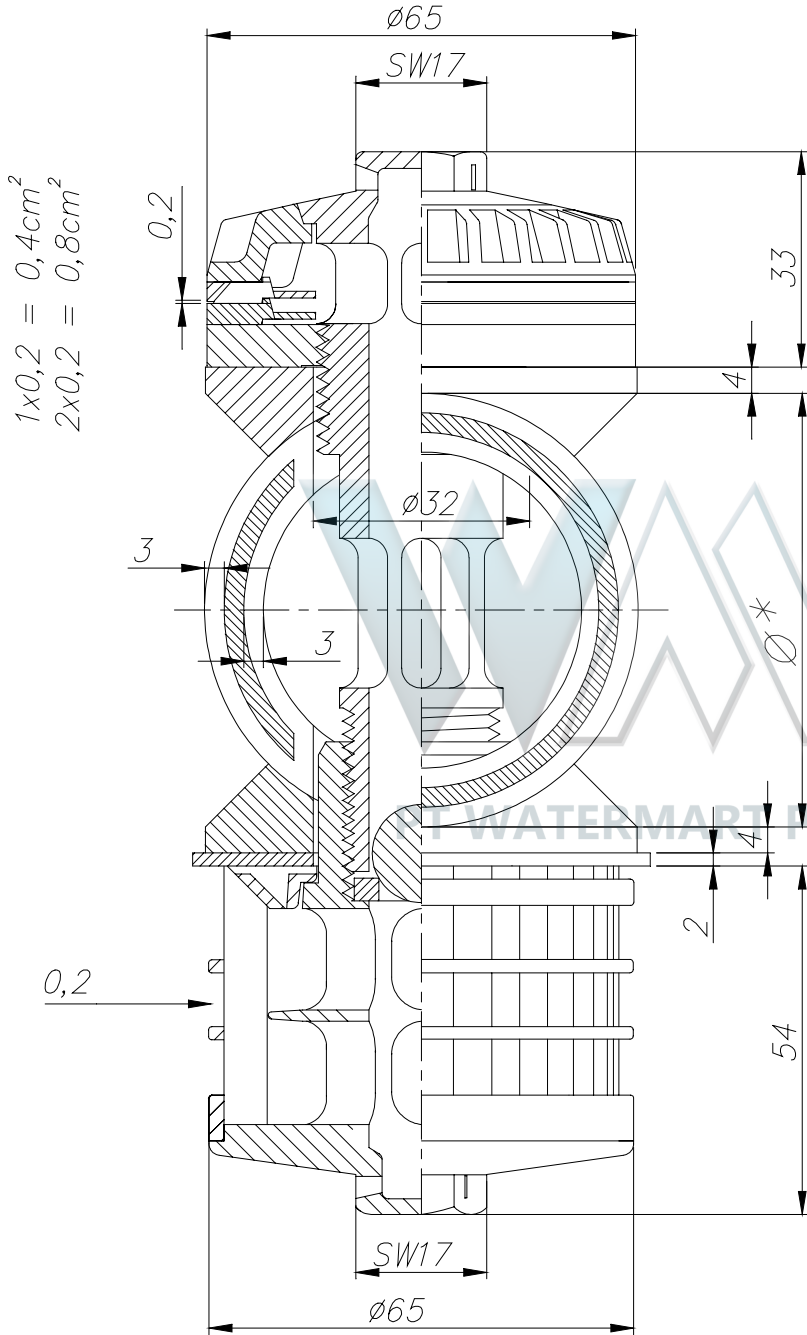

Bestellung Ordering Commande Encargo	Typ Type Type Tipa	Schlitze Slots Fentes Ranuras	Ø*
	MST	1x 0,2 = 0,4 cm²	Ø 63
		2x 0,2 = 0,8 cm²	Ø 75
			Ø 90
			Ø 114

Filterdüzensatz
für
Zwischenböden

Filter-Nozzles-Set
for intermediate
Bottoms

Crepine a Filtre
assortiment pour
fonds intermediaires

Conjunto de
toberas para
placas intermedias

Typ P-0,2 / C2-0,2-24

Bestellbeispiel
Example for Ordering
Exemple de commande
Ejemplo de encargo

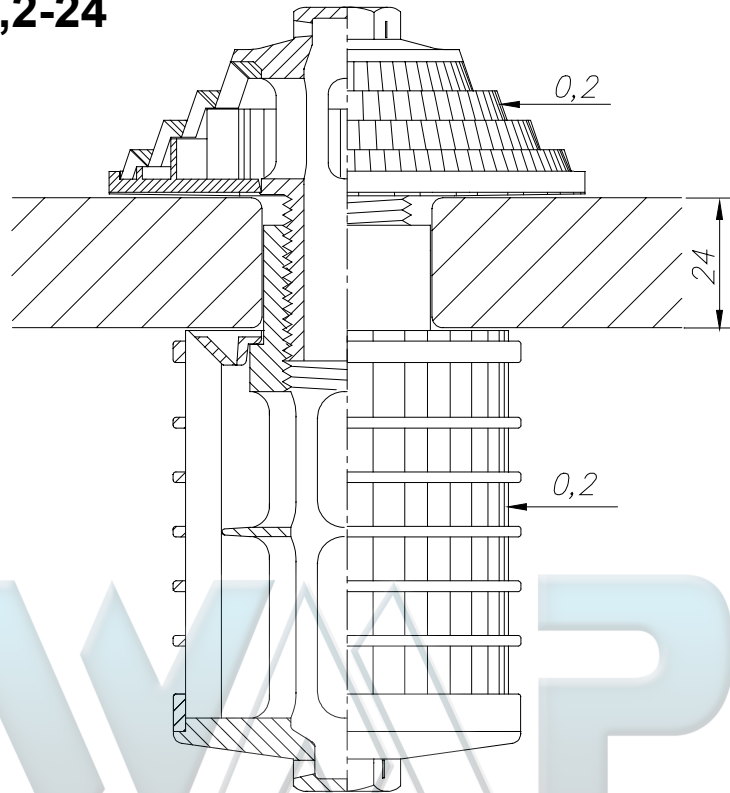

PT WATERMART PERKASA

Typ C1-0,3 / C1-0,2-35-F

Bestellbeispiel
Example for Ordering
Exemple de commande
Ejemplo de encargo

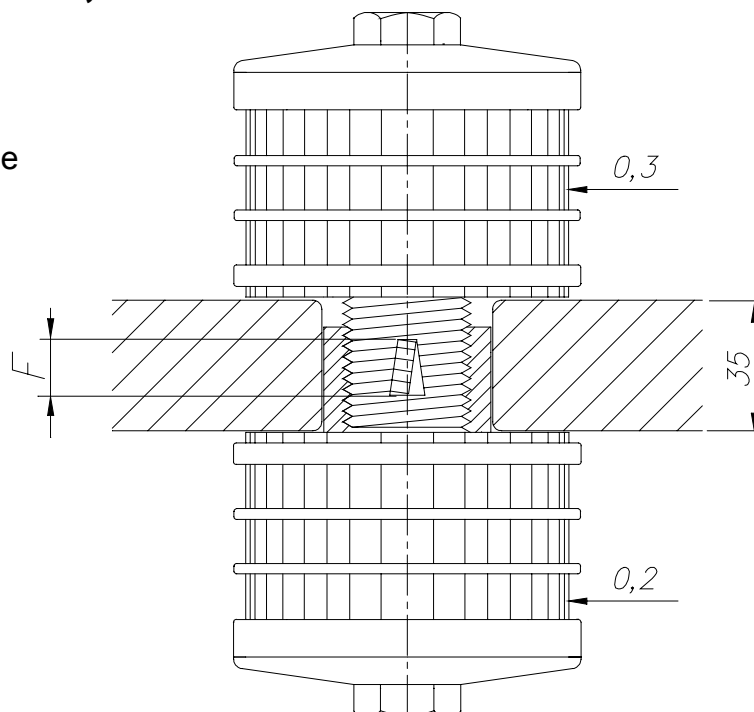

F = Lösungssicherung
F = special devise (Flipper)
F = Dispositif auto bloquant
F = Cierrede Seguridad

Filterdüzensatz
für Zwischenböden

Filter-Nozzles-Set
For intermediate bottoms

Crépines à filtre
Assortiment pour planches
intermédiaies

Conjuto de
Toberas para
placas intermedias

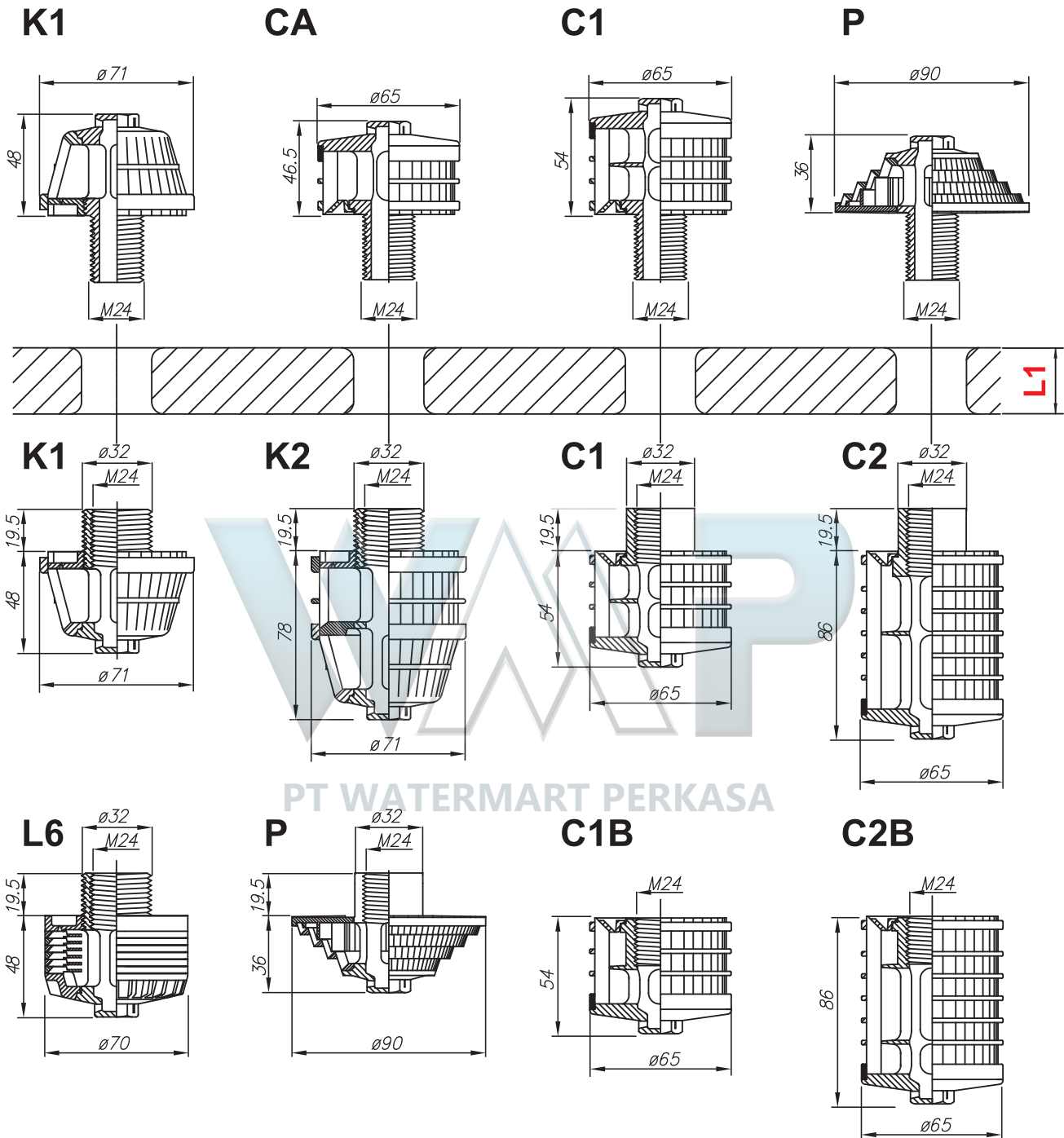

Bestellung Ordering Commande Encargo	Typ obere Düse Type upper nozzle Type crépines supérieures Tipo toberas Superior	Schlitze Slots Fentes Ranuras	Typ untere Düse Type lower nozzle Type crépines inférieures Tipo tobera Inferior	Schlitze Slots Fentes Ranuras	Bodenstärke Plate thickness Epaisseur du plancher Espesor placa
✉	K1	0,2 0,35 0,5	K1	0,2 0,35 0,5 - 2,0	
	C1	0,2 0,3 0,5	K2	0,2 0,35	
	P	0,2	C1	0,2 0,3 0,5 - 2,0	
	CA	0,4	C1B	0,2 0,3 0,5 - 2,0	
			C2	0,2 0,3	
			C2B	0,2 0,3	
			L	0,2 0,3 0,5	
			P	0,2	

L1 = mm

Gegenstromventil

Zur besseren Verteilung der Regeneriermittel

Counter Flow Valve

For the uniform distribution of the regenerants

Soupape à contre

Pour une meilleure répartition des solutions de régénération

Valvula de contra

Para la distribución uniforme de los reactivos de regeneracion

Typ GUV

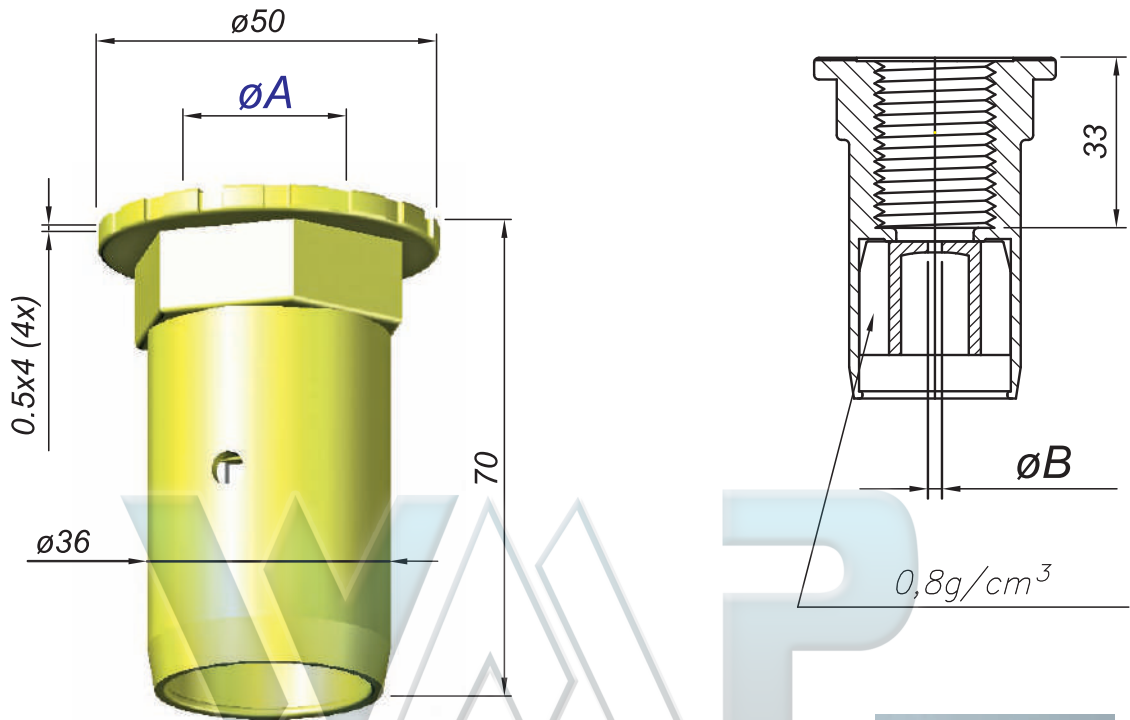

PT WATERMART PERKASA

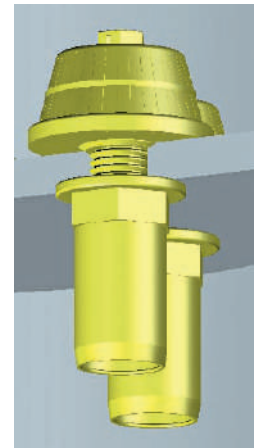
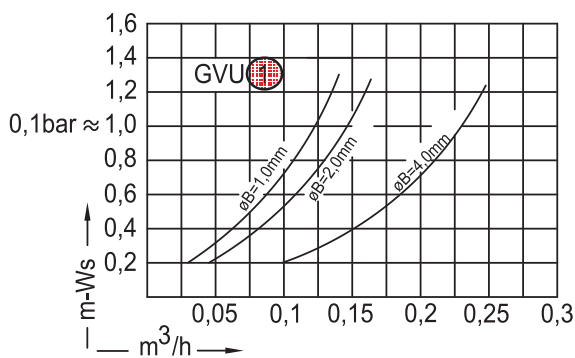

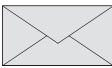
Bestellung Ordering Commande Encargo	Typ Type Type Tipa	Gewinde Thread Filetage Rosca	ϕA	ϕB
	GVU	1 1/4" WW	32	$\phi 1,0 - \phi 2,0 - \phi 3,0 - \phi 4,0 - \phi 5,0 - \phi 6,0 - \phi 7,0$ mm
		G 3/4"	26,5	
		M24	24	
		M20	20	

Gegenstromventil

Zur besseren Verteilung der Regeneriermittel

Counter Flow Valve

For the uniform distribution of the regenerants

Soupape à contre

Pour une meilleure répartition des solutions de régénération

Valvula de contra

Para la distribución uniforme de los reactivos de regeneracion

Typ GVO

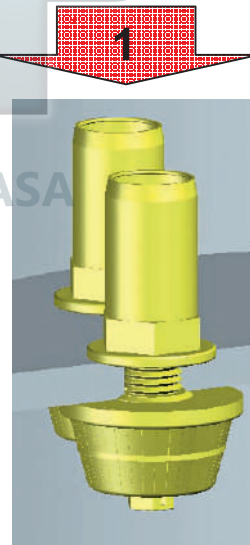
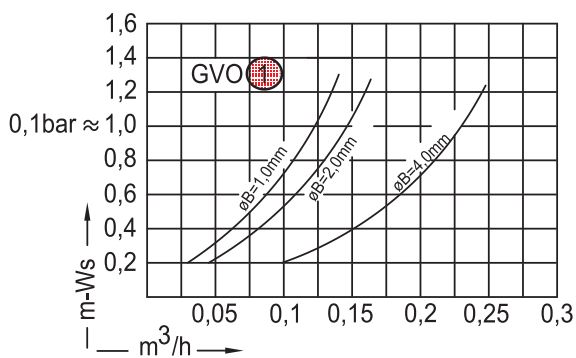
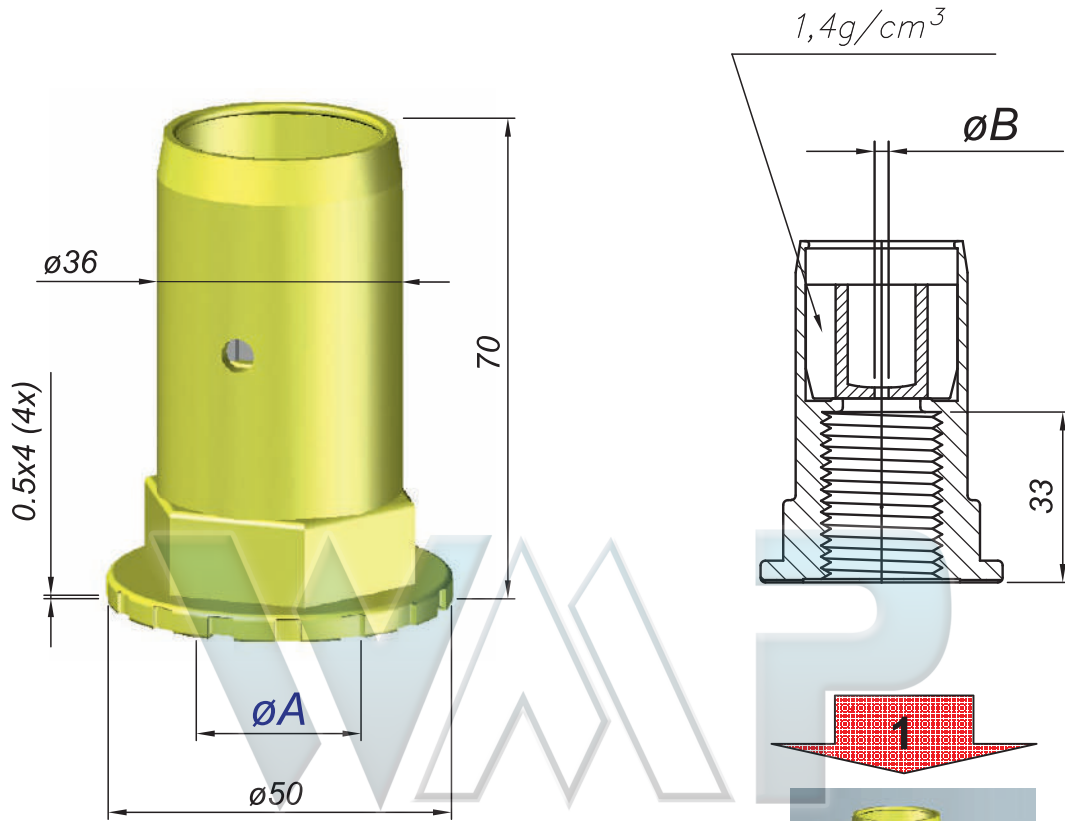

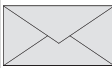
Bestellung Ordering Commande Encargo	Type Type Type Tipa	Gewinde Thread Filetage Rosca	øA	øB
	GVO	1¼" WW	32	ø1,0 - ø2,0 - ø3,0 - ø4,0 - ø5,0 - ø6,0 - ø7,0 mm
		G 3/4"	26,5	
		M24	24	
		M20	20	

Filterdüsen

Zur besseren Verteilung der Regeneriermittel

Filter-Nozzles

For the uniform distribution of the regenerants

Crépines à filtre

Pour une meilleure répartition des solutions de régénération

Toberas filtrantes

Para la distribución uniforme de los reactivos de regeneracion

Typ PKU

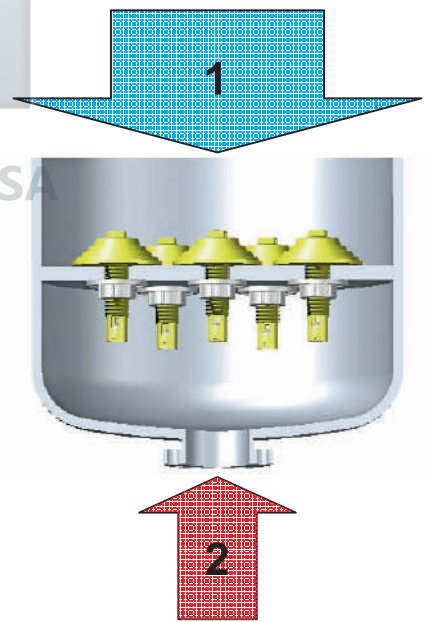
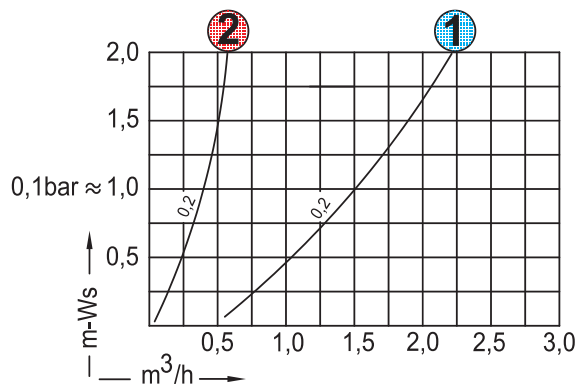
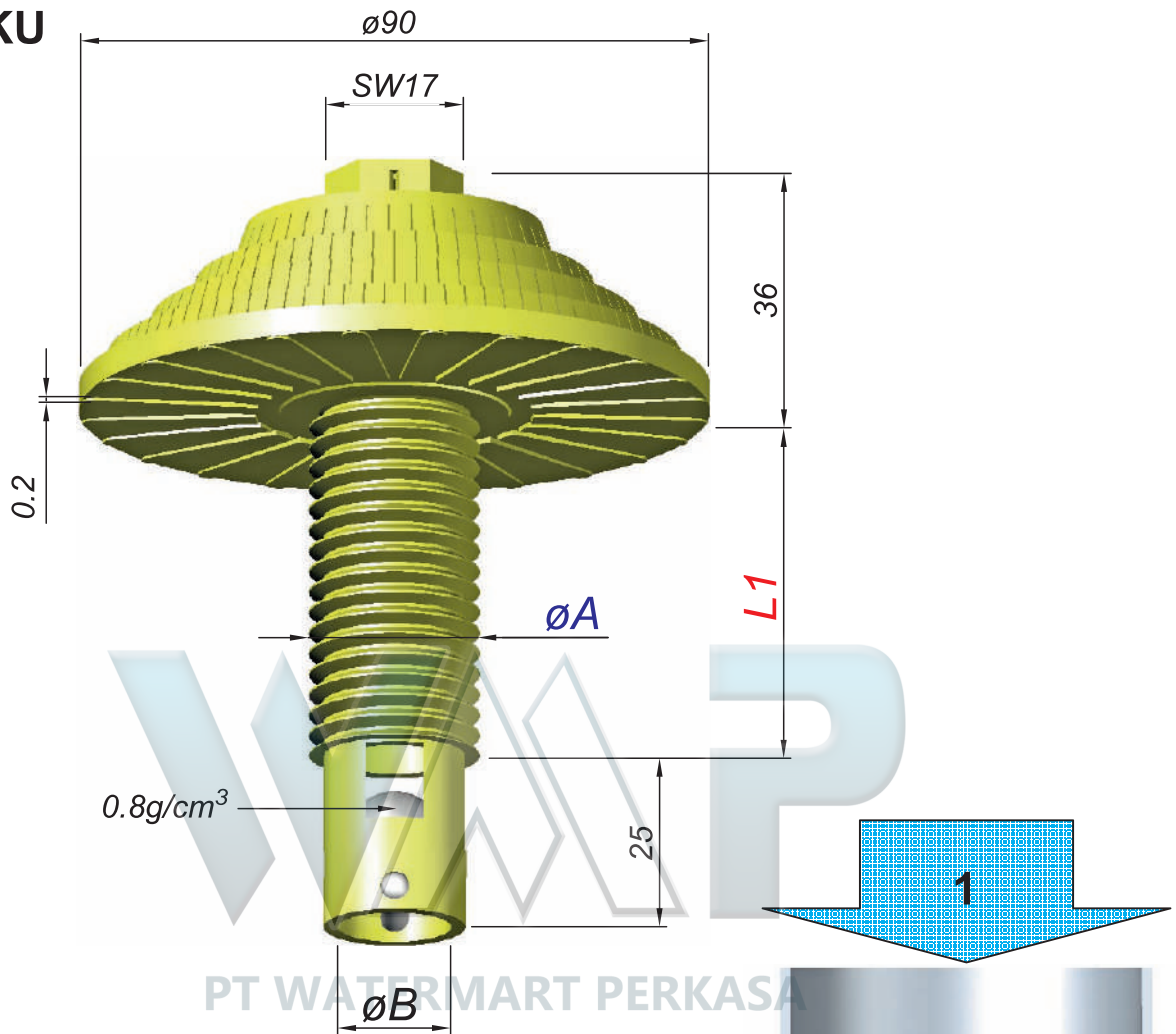

Bestellung Ordering Commande Encargo	Typ Type Type Tipa	Schlitze Slots Fentes Ranuras	Gewinde Thread Filetage Rosca	øA	L1	øB
	PKU	0,2 = 3,0 cm ²	M24	24	45, 50, +5 +5...	16 = 2,0 cm ²

Filterdüsen

Zur besseren Verteilung der Regeneriermittel

Filter-Nozzles

For the uniform distribution of the regenerants

Crépines à filtre

Pour une meilleure répartition des solutions de régénération

Toberas filtrantes

Para la distribución uniforme de los reactivos de regeneración

Typ PKO

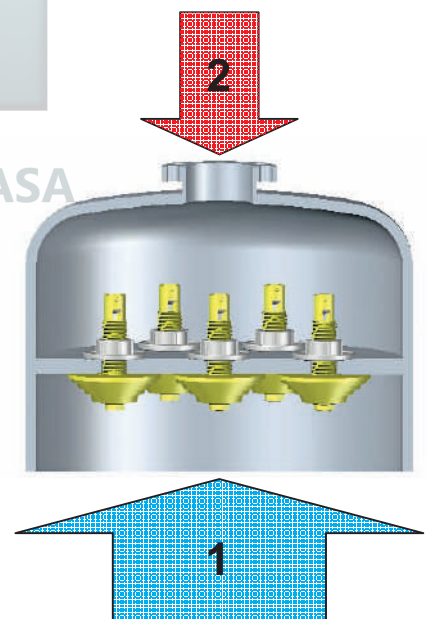
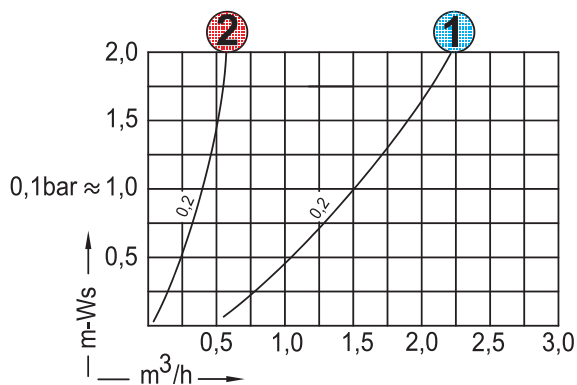
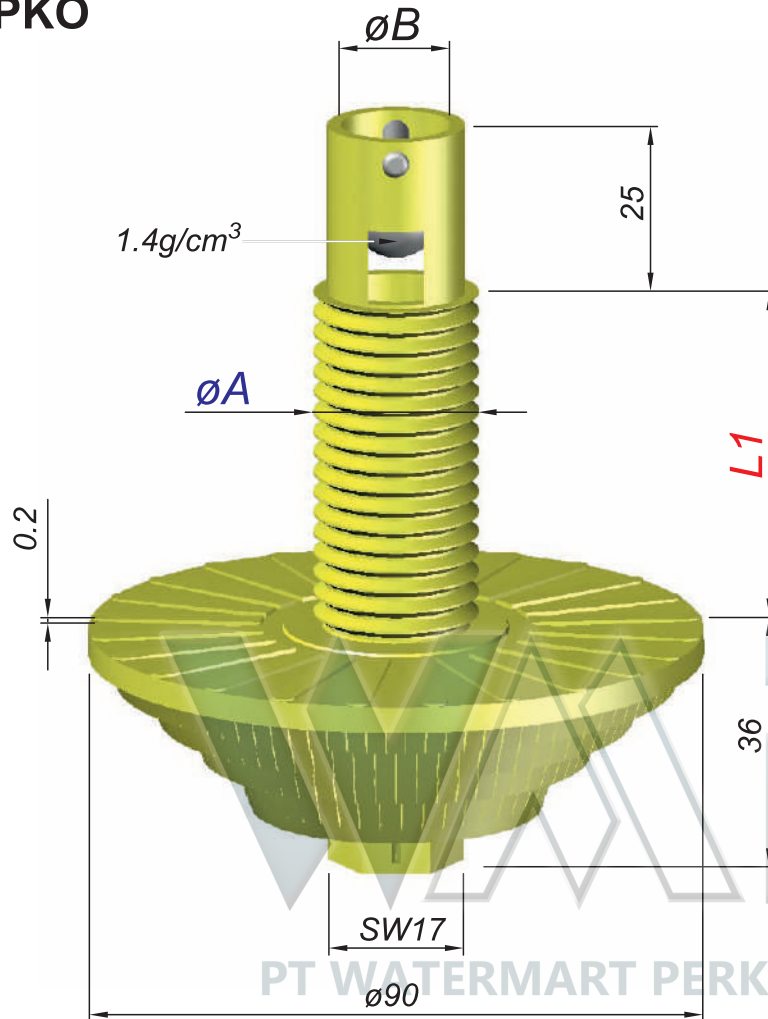

Bestellung Ordering Commande Encargo	Type Type Type Tipa	Schlitz Slots Fentes Ranuras	Gewinde Thread Filetage Rosca	$\varnothing A$	L1	$\varnothing B$
	PKO	0,2 = 3,0 cm ²	M24	24	45, 50, +5 +5...	16 = 2,0 cm ²

Mischbett
Filterdüsen

Mixbed
Filter-Nozzles

Crépines à filtre
Pour lit mélange

Toberas filtrantes
Para lechos mixtos

Typ M

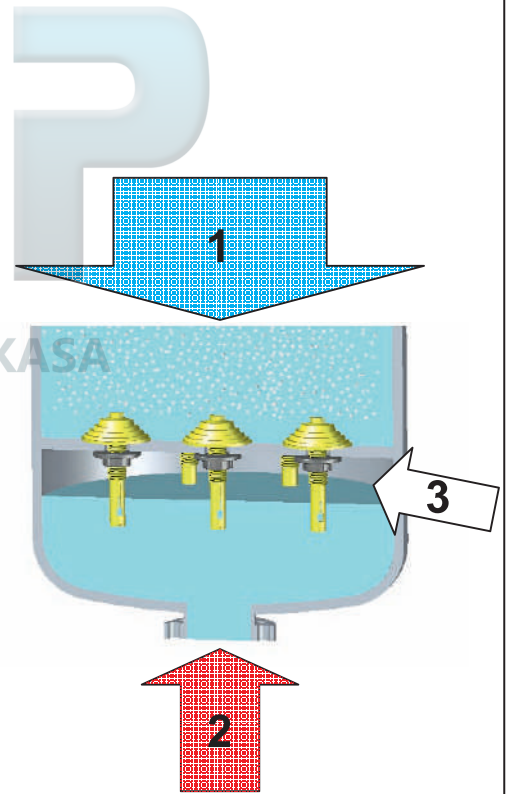
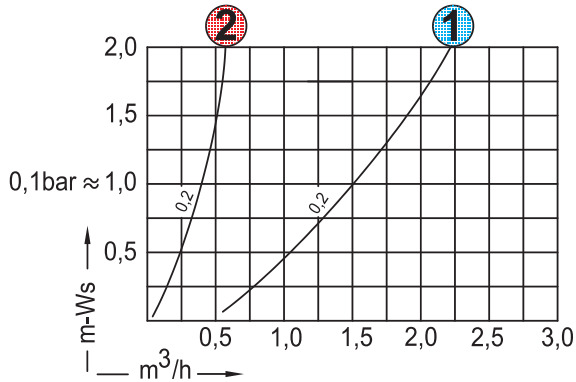
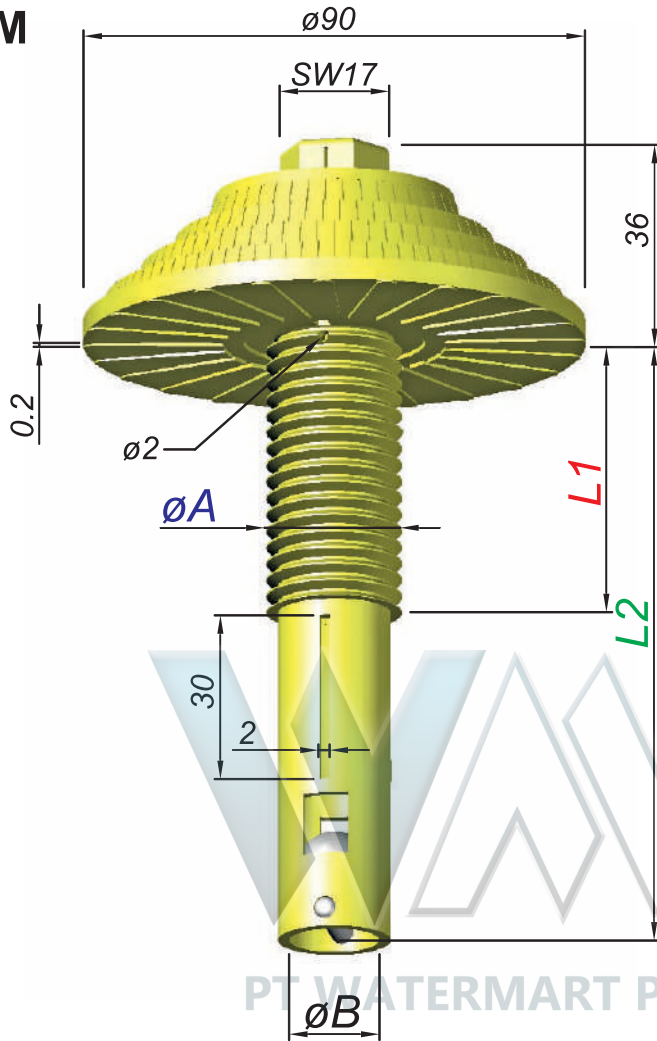

Bestellung Ordering Commande Encargo	Typ Type Type Tipa	Schlitze Slots Fentes Ranuras	Gewinde Thread Filetage Rosca	$\varnothing A$	Gewindelänge Thread length Longueur de filetage Largura de la rosca	Schaft Shaft Longueur de tige Tija	$\varnothing B$
✉	M	0,2 = 3,0 cm ²	G 3/4"	26,5	50	110	16 = 2,0 cm ²
			M24	24			

Filterdüsen

Filter-Nozzles

Crépines à filtre

Toberas filtrantes

Typ MDL

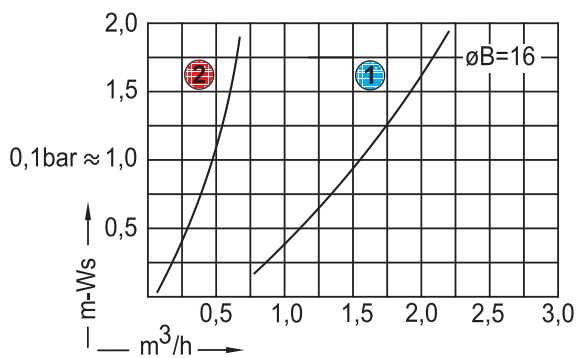
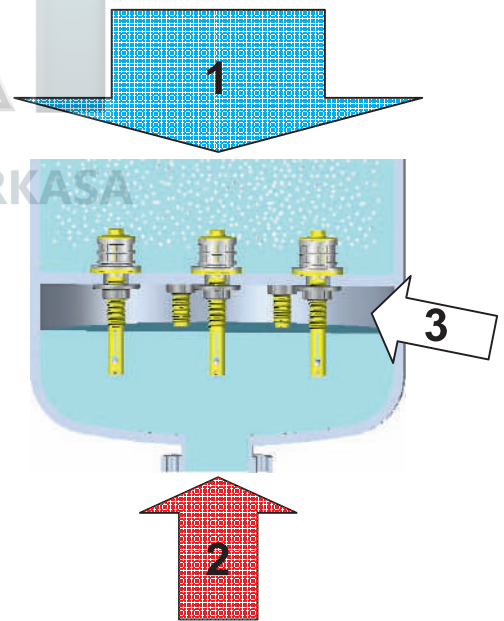
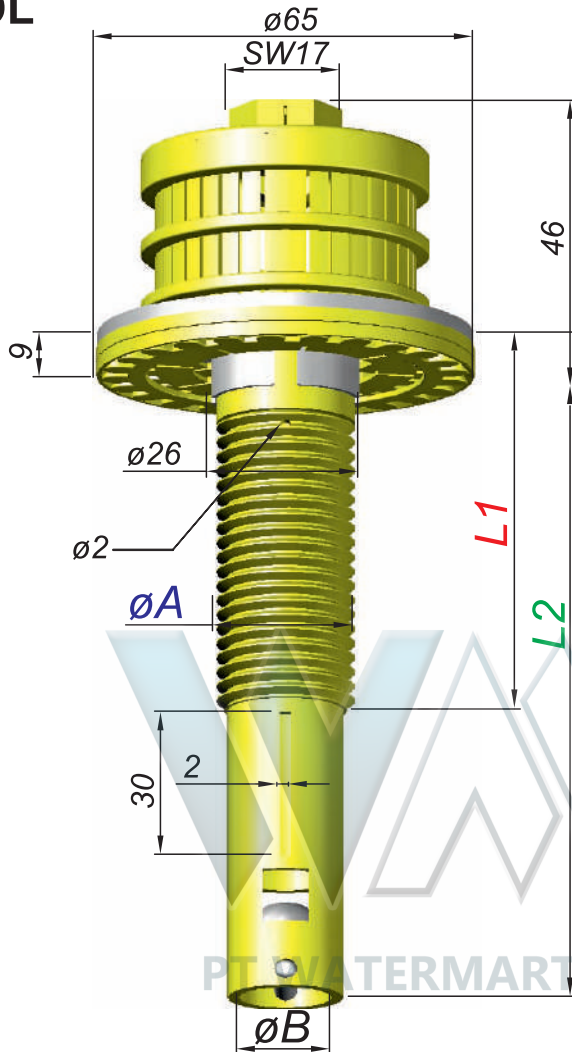

Bestellung Ordering Commande Encargo	Typ Type Type Tipa	Schlitz Slots Fentes Ranuras	Gewinde Thread Filetage Rosca	$\varnothing A$	Gewindelänge Thread length Longueur de filetage Largura de la rosca	Schaft Shaft Longueur de tige Tija	$\varnothing B$
					L1	L2	
	MDL	24 x 0,2 = 0,91 cm ² 36 x 0,2 = 1,37 cm ²	M24	24	60	120	16 = 2,0 cm ²

Filterdüsen für Drainagesystem

Filter-Nozzles for Drainage system

Système de drainage

Sistemas de drenaje

Montagebeispiel

Installation procedure

Exemple de montage

Ejemplo de montaje

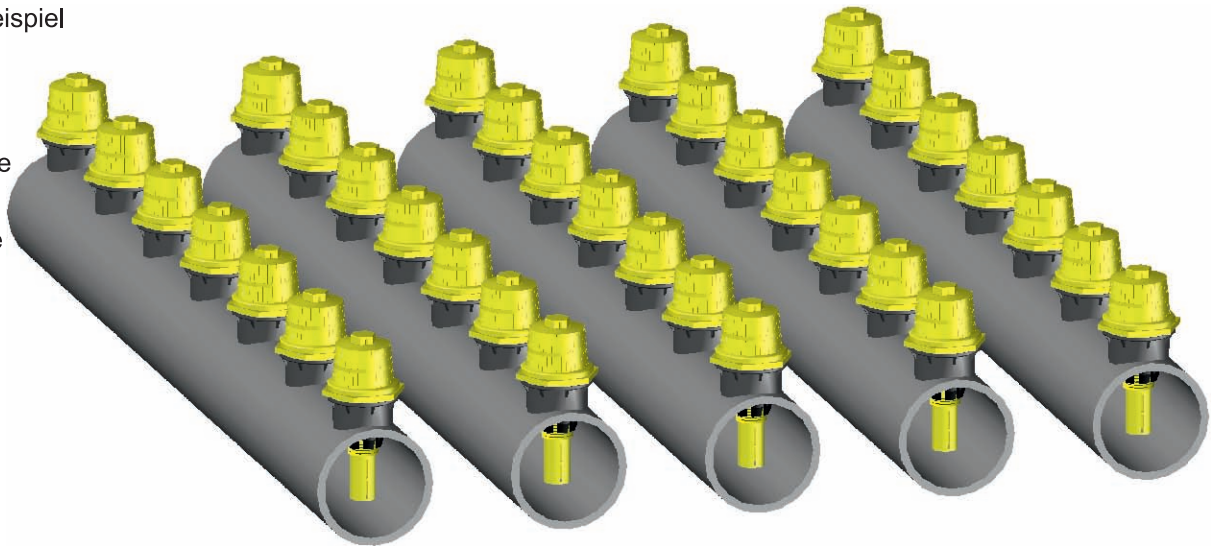

Typ ADR

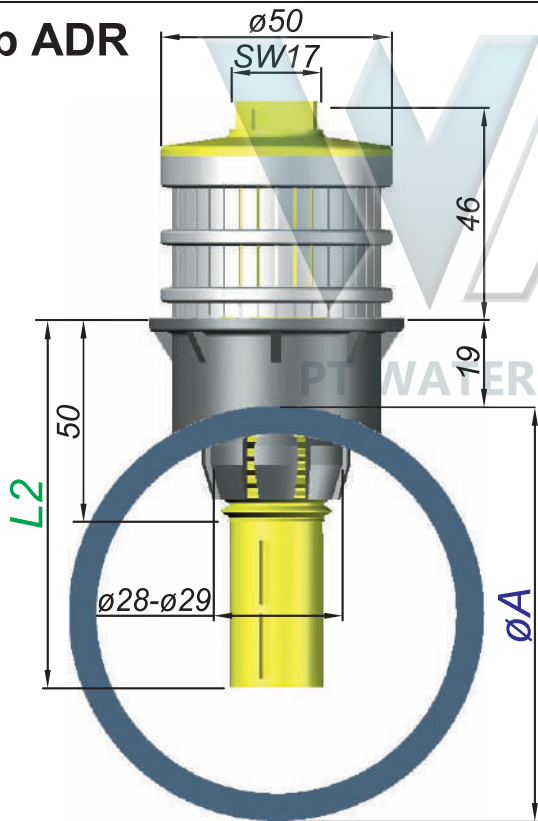

Typ ASR

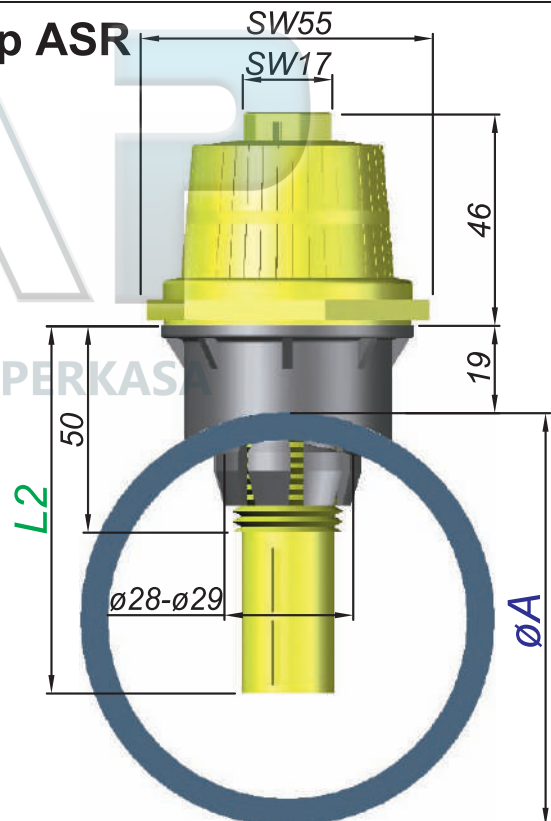

Bestellung Ordering Commande Encargo	Typ Type Type Tipa	Schlitz Slots Fentes Ranuras	$\varnothing A$	Schaft Shaft Longueur de tige Tija	Bestellung Ordering Commande Encargo	Typ Type Type Tipa	Schlitz Slots Fentes Ranuras	$\varnothing A$	Schaft Shaft Longueur de tige Tija
	ADR	24 x 0,2 = 0,91 cm ² 36 x 0,2 = 1,37 cm ² 36 x 0,3 = 2,05 cm ² 36 x 0,5 = 3,42 cm ² 36 x 0,8 = 5,46 cm ² 24 x 1,0 = 4,56 cm ² 24 x 1,5 = 6,84 cm ² 20 x 2,0 = 7,00 cm ² 8 x 5,0 = 7,00 cm ²	60,3 63 75 90 110	Nach Angabe according detail selon détails adecuado detalle		ASR	36 x 0,2 = 1,72 cm ² 36 x 0,35 = 2,65 cm ² 30 x 0,5 = 3,78 cm ² 18 x 1,0 = 4,64 cm ² 18 x 2,0 = 9,29 cm ²	60,3 63 75 90 110	Nach Angabe according detail selon détails adecuado detalle

Filterdüsen für Drainagesystem	Filter-Nozzles for Drainage system	Système de drainage	Sistemas de drenaje
--------------------------------	------------------------------------	---------------------	---------------------

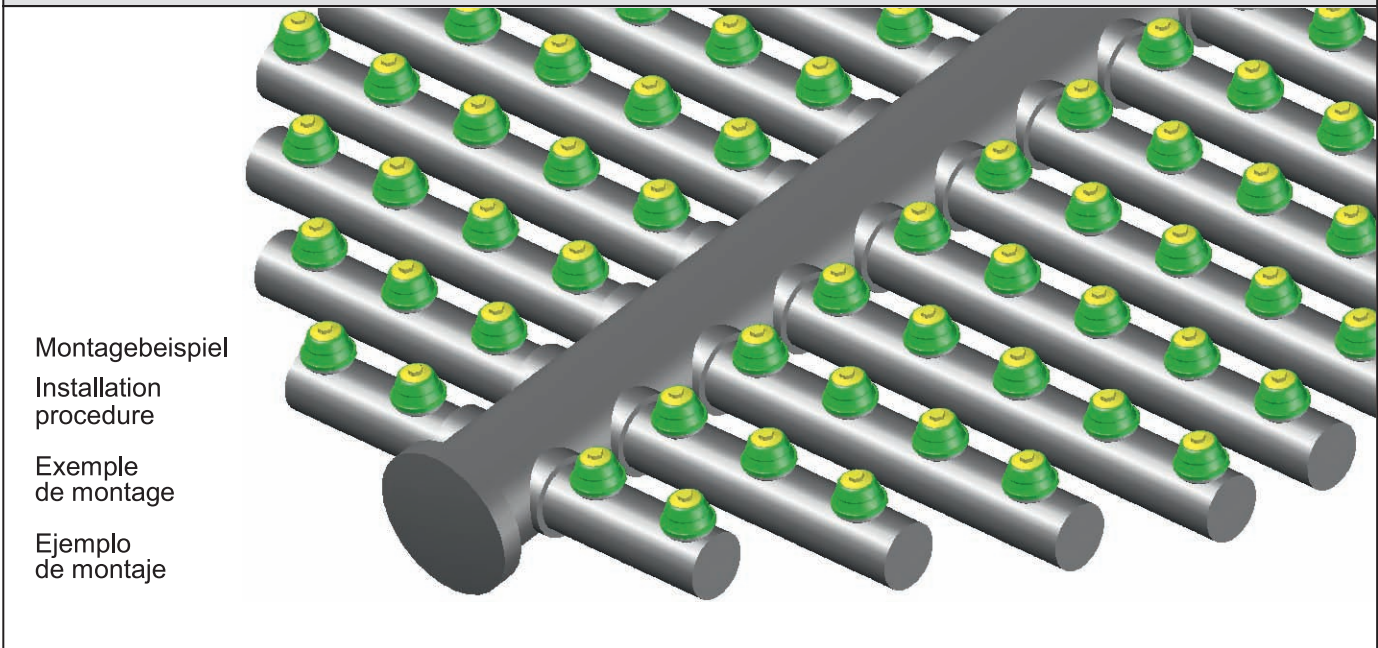

Montagebeispiel
 Installation procedure
 Exemple de montage
 Ejemplo de montaje

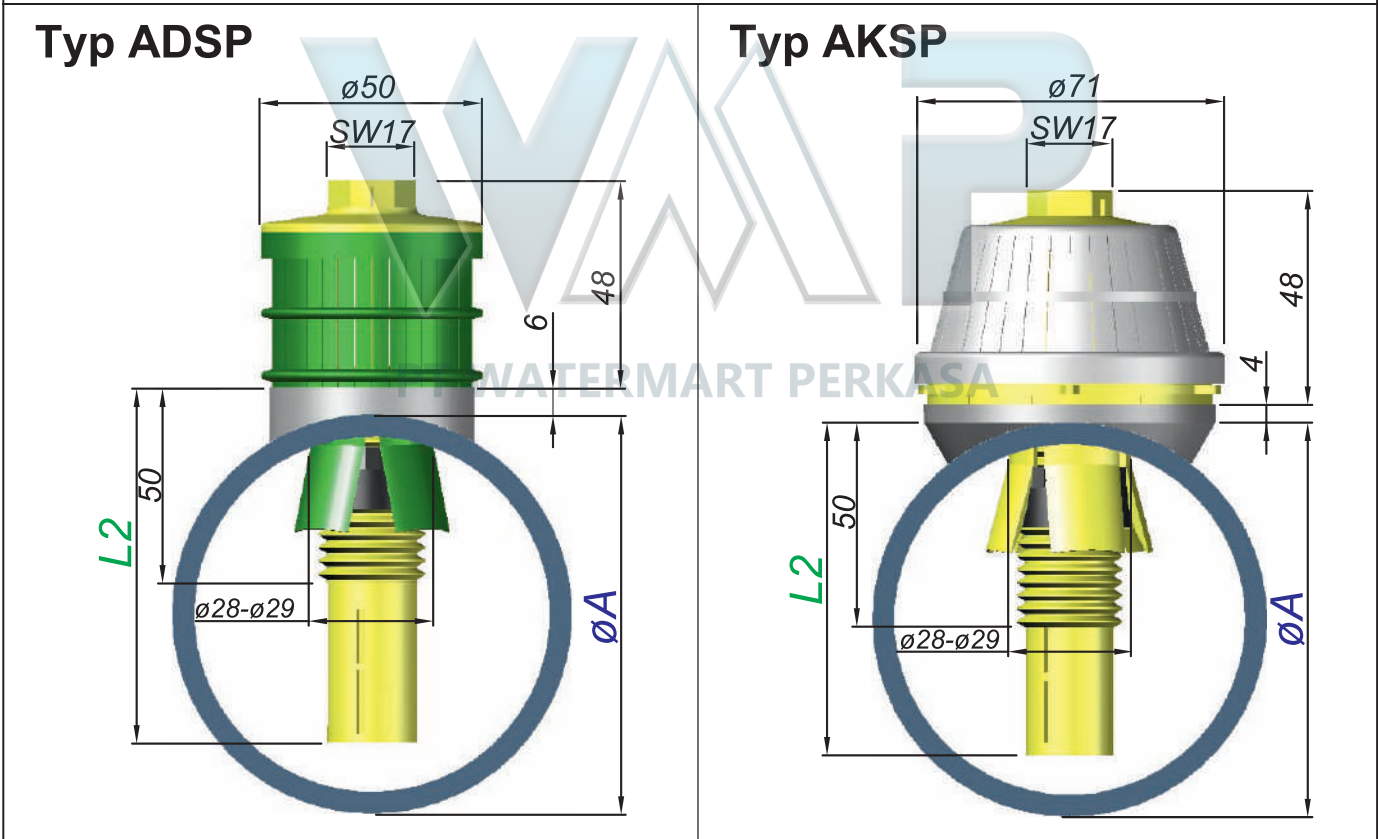

Bestellung Ordering Commande Encargo	Typ Type Type Tipa	Schlitze Slots Fentes Ranuras	ØA	Schaft Shaft Longueur de tige Tija	L2	Bestellung Ordering Commande Encargo	Typ Type Type Tipa	Schlitze Slots Fentes Ranuras	ØA	Schaft Shaft Longueur de tige Tija	L2
	ADSP	36 x 0,2 = 1,37 cm ² 36 x 0,3 = 2,05 cm ² 36 x 0,5 = 3,42 cm ² 36 x 1,0 = 6,84 cm ²	60,3 63 75 90 114 147 165 219 273 324	Nach Angabe according detail selon détails adecuado detalle			AKSP	40 x 0,2 = 1,95 cm ² 36 x 0,35 = 2,96 cm ² 20 x 0,5 = 2,35 cm ² 36 x 0,5 = 4,23 cm ² 20 x 0,8 = 3,78 cm ² 36 x 1,0 = 8,46 cm ² 24 x 1,5 = 7,05 cm ² 20 x 2,0 = 9,50 cm ²	60,3 63 75 90 114 147 165 219 273 324	Nach Angabe according detail selon détails adecuado detalle	

**Filterdüsen für
Drainagesystem**

**Filter-Nozzles for
Drainage system**

**Systemes de
drainage**

**Sistemas de
drenaje**

Montagebeispiel

Installation
procedure

Exemple
de montage

Ejemplo
de montaje

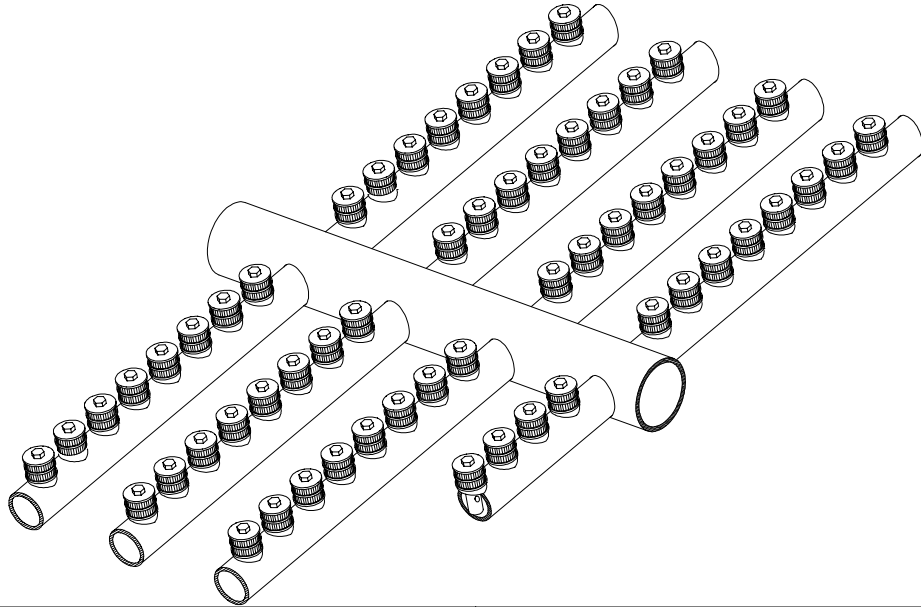

Typ ATSP

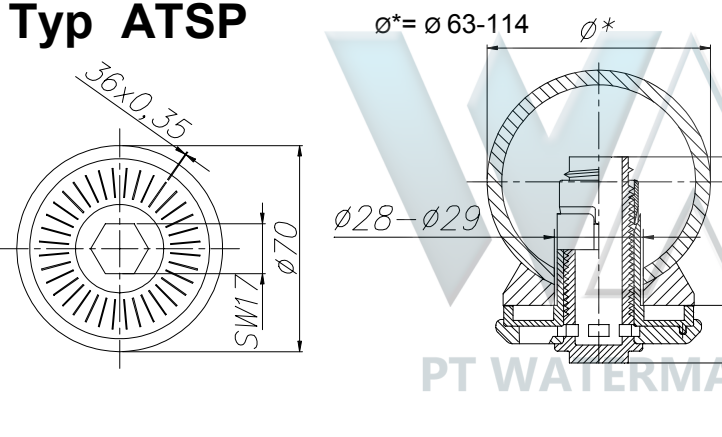

Typ S1DR

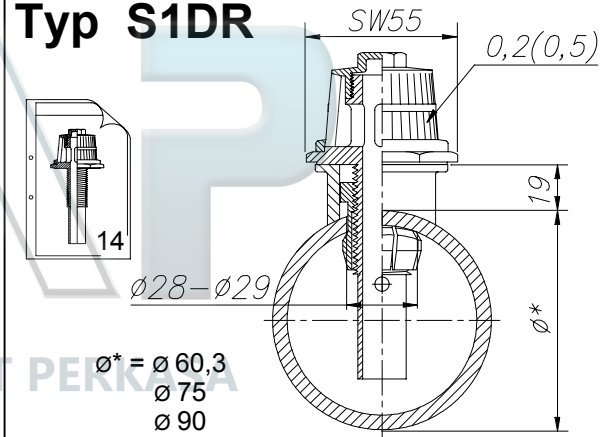

ATSP- 0,35 - \varnothing^* mm



S1DR- (0,2-0,5) - \varnothing^* mm

Typ ADSP

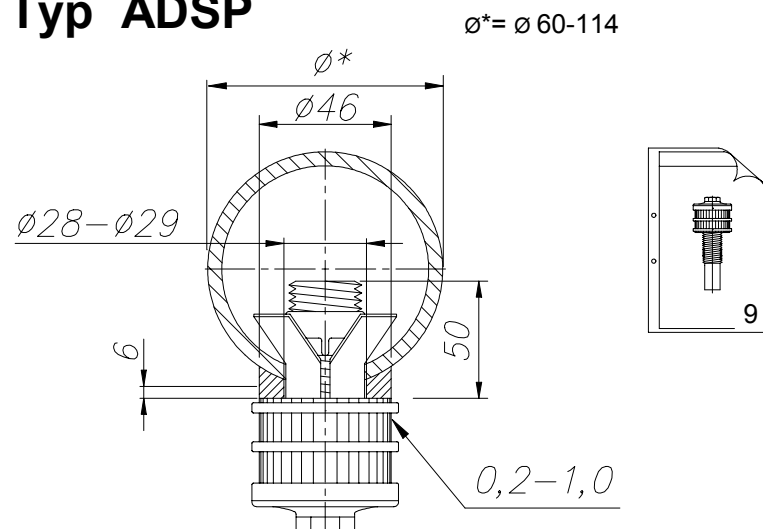

Typ AKSP

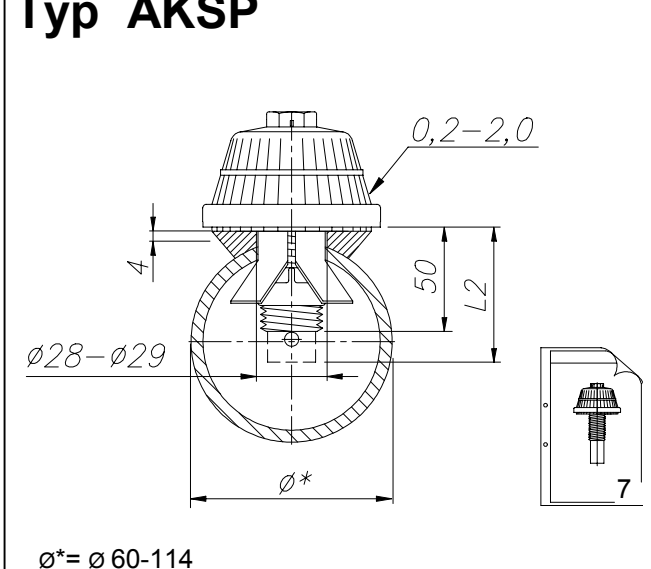

ADSP- (0,2-1,0) - \varnothing^* mm

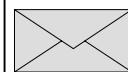

AKSP- (0,2-2,0) - \varnothing^* mm-L2 mm

Filterdüsen für Drainagesystem

Filter-Nozzles for Drainage system

Système de drainage

Sistemas de drenaje

Montagebeispiel

Installation procedure

Exemple de montage

Ejemplo de montaje

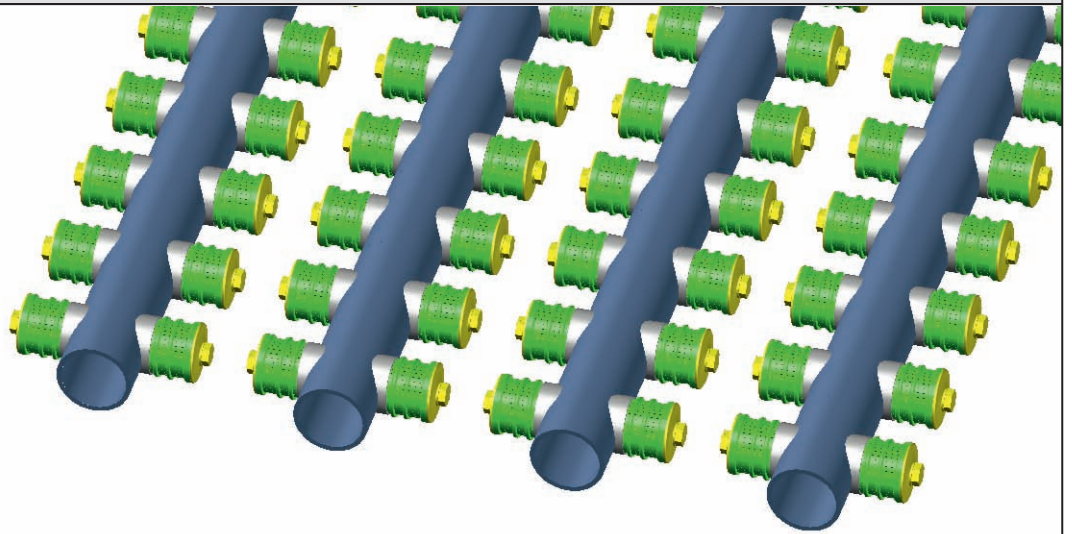

Typ DDR

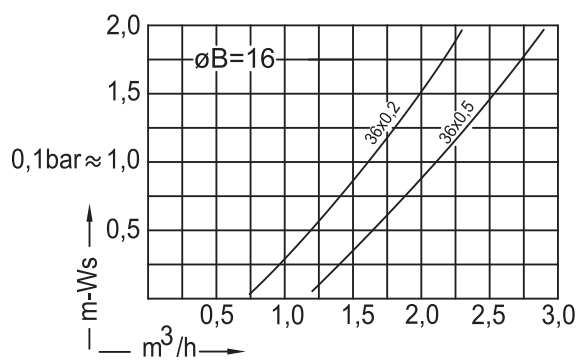
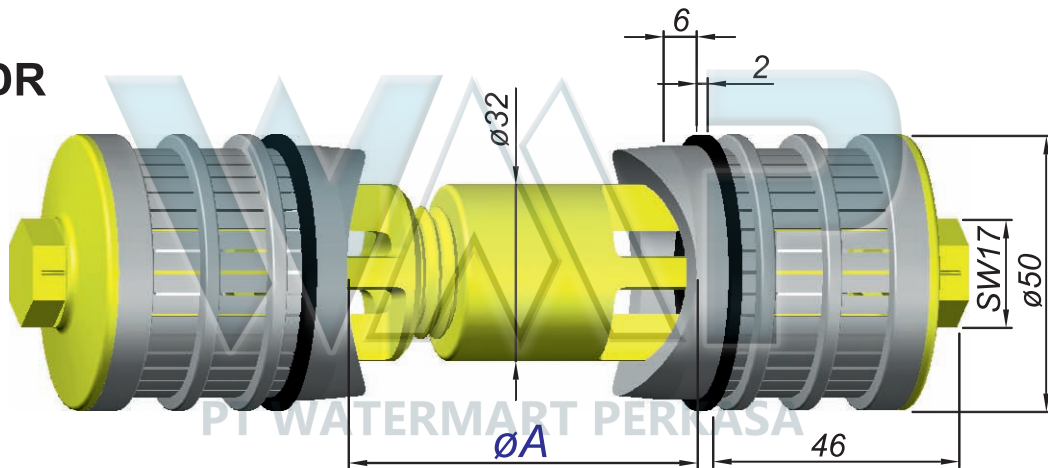

Bestellung Ordering Commande Encargo	Typ Type Type Tipa	Schlitze Slots Fentes Ranuras	øA
	DDR	24 x 0,2 = 0,91 cm ² 36 x 0,2 = 1,37 cm ² 36 x 0,3 = 2,05 cm ² 36 x 0,5 = 3,42 cm ² 12 x 0,8 = 1,82 cm ² 12 x 1,0 = 2,28 cm ² 24 x 1,0 = 4,56 cm ² 24 x 1,5 = 6,84 cm ² 20 x 2,0 = 7,00 cm ² 8 x 5,0 = 7,00 cm ²	60,3 ; 63 ; 75 ; 90 ; 114 ; 147 ; 165 ; 219 ; 273 ; 324

Filterdüsen für Drainagesystem	Filter-Nozzles for Drainage system	Système de drainage	Sistemas de drenaje
-----------------------------------	---------------------------------------	------------------------	------------------------

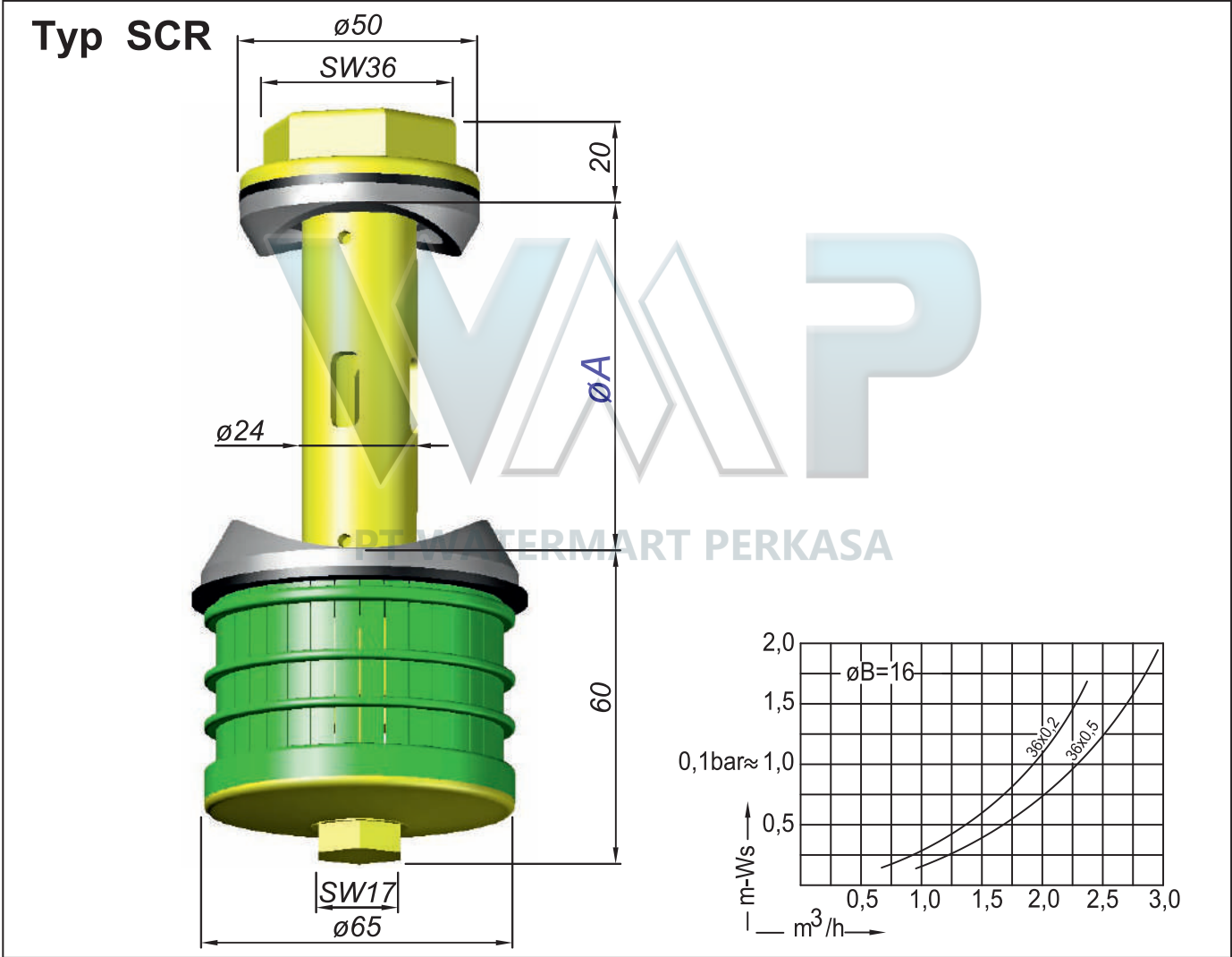
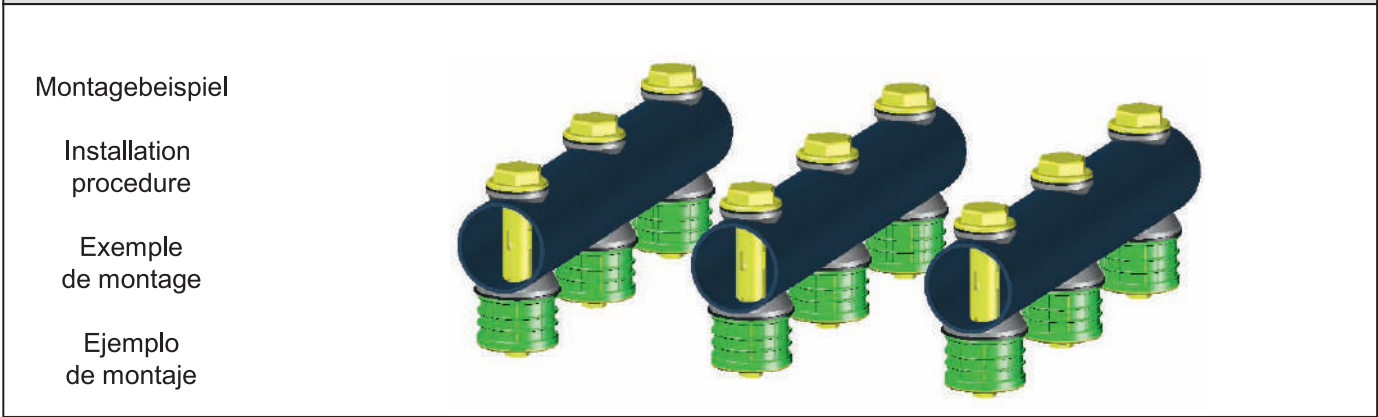

Bestellung Ordering Commande Encargo	Typ Type Type Tipa	Schlitze Slots Fentes Ranuras	$\varnothing A$
	SCR	36 x 0,2 = 1,95 cm ² 36 x 0,3 = 2,90 cm ² 36 x 0,5 = 4,90 cm ² 36 x 0,7 = 6,80 cm ² 36 x 1,0 = 9,80 cm ²	60,3 ; 63 ; 75 ; 90 ; 114 ; 147 ; 165 ; 219 ; 273 ; 324

Filterdüsen für
Drainagesystem

Filter-Nozzles for
Drainage system

Systemes de
drainage

Sistemas de
drenaje

Typ DDR

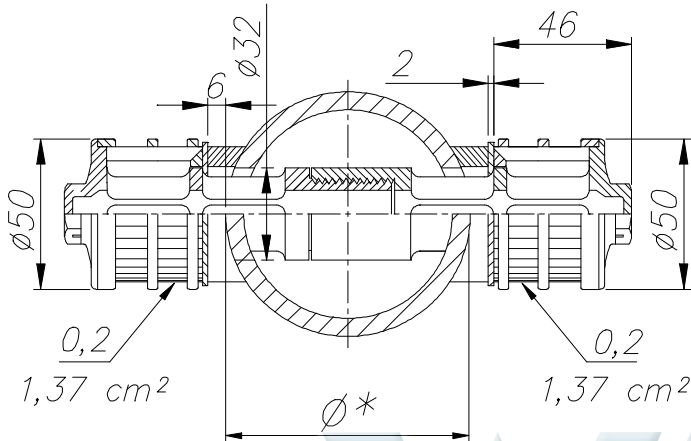

Typ SLR

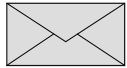
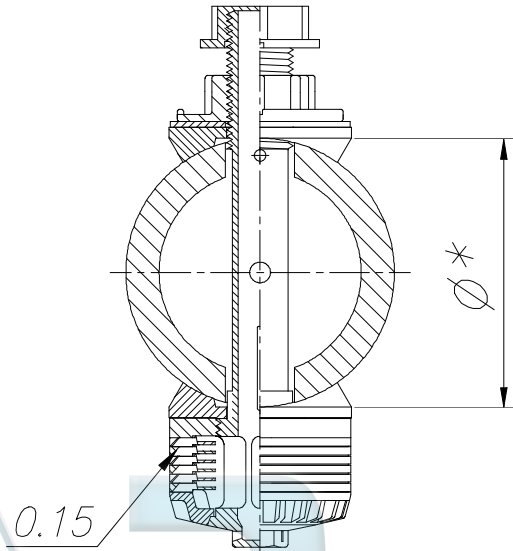

DDR-0,2/0,2- Ø *mm



SLR-0,15- Ø *mm

Typ SCR

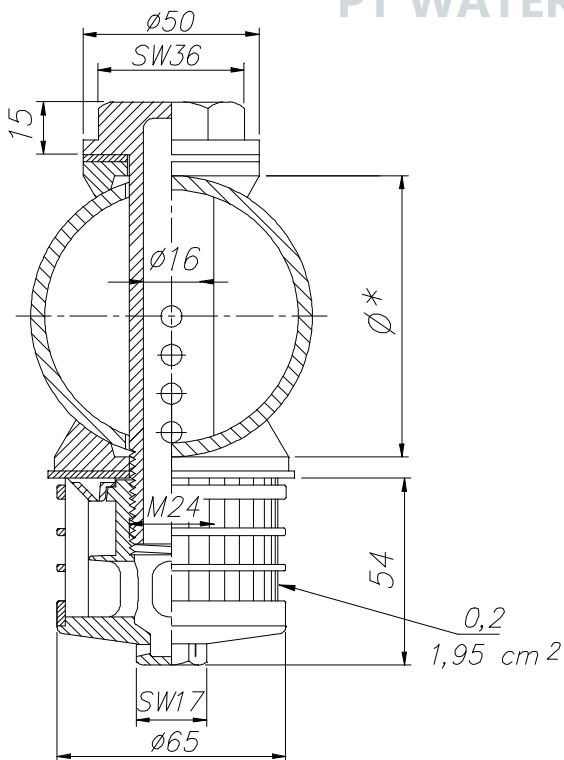

Typ DD

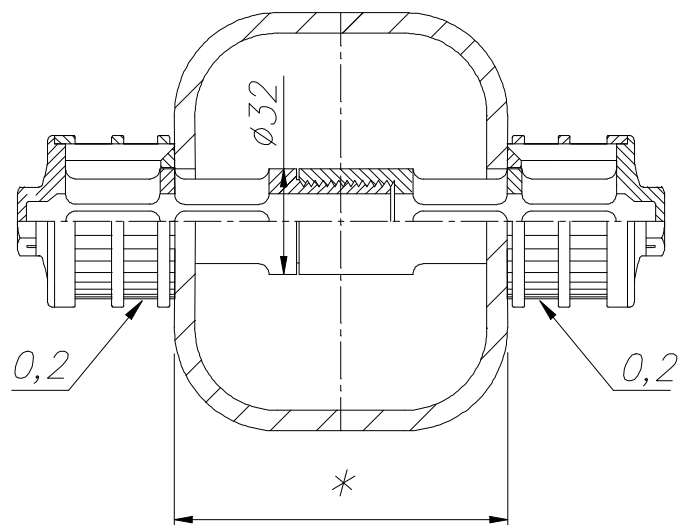

SCR-0,2- Ø *mm



DD-0,2/0,2- *mm

Muttern und Scheiben	Nuts and Washers	Ecrous et joints	Tuerca y Arandela					
Typ MU43		Bestellung Ordering Commande Encargo	Typ Type Type Tipa	Gewinde Thread Filetage Rosca øA				
			MU43	1" WW M24 M22x1,5 M20	G1/2" G3/8"			
Typ MU60		Bestellung Ordering Commande Encargo	Typ Type Type Tipa	Gewinde Thread Filetage Rosca øA				
			MU60	1 1/4" WW 1" WW G 3/4" M24 M22x1,5 M20				
Typ MUZ		Bestellung Ordering Commande Encargo	Typ Type Type Tipa	Gewinde Thread Filetage Rosca øA	øB			
			MUZ	M24 1 1/4" WW G 3/4" M24	50 60			
Typ MU84		Bestellung Ordering Commande Encargo	Typ Type Type Tipa	Gewinde Thread Filetage Rosca øA				
			MU84	G 2" G 1 1/2"				
Typ SR50		Bestellung Ordering Commande Encargo	Typ Type Type Tipa	Gewinde Thread Filetage Rosca øA	L1			
			SR50	1 1/4" WW G 1" G 3/4" M24	32 33,25 26,5 24	...mm		
Typ DP Typ DG		Bestellung Ordering Commande Encargo	Typ Type Type Tipa	øA	øB		S	Material Material Material Material
			DP	50 70	32; 30; 28; 25; 21 32; 25 32; 30; 25 32; 30; 28; 25; 21 32; 30; 28	2 5 7 2 7	PP	
			DG	50 70 90	32; 28; 25; 21	2	EPDM (KTW)	

Dübel	Expanding ring (dowel)	Douilles expansives	Anillas de expansion
-------	------------------------	---------------------	----------------------

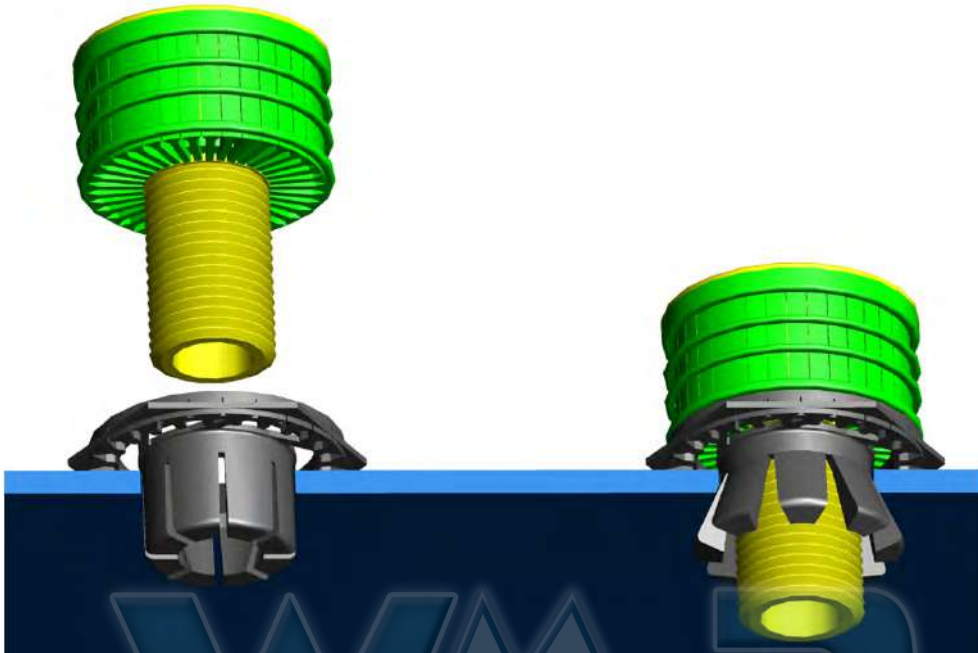

Typ DB50

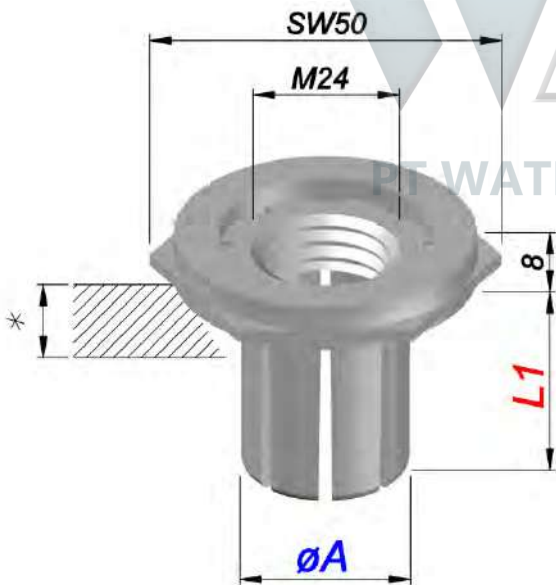

Typ DB65

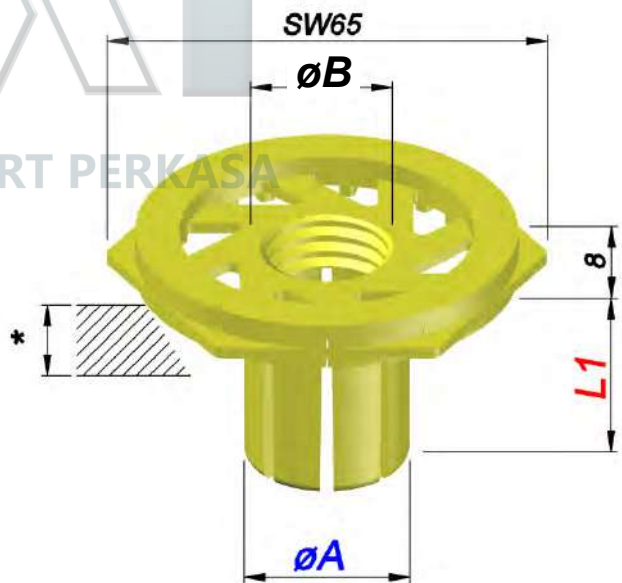

Bestellung Ordering Commande Encargo	Typ Type Type Tipa	øA	Bodenstärke plate thickness Epaisseur du plancher Espesor placa	*	L1	Bestellung Ordering Commande Encargo	Typ Type Type Tipa	øA	Bodenstärke plate thickness Epaisseur du plancher Espesor placa	*	øB	L1
✉	DB50	ø28	8 - 12 - elfenbein / ivory	36	36	✉	DB65	ø28	8 - 12 - elfenbein / ivory	M24	M24	36
			12 - 17 - grau / grey						12 - 17 - grau / grey			
			17 - 22 - schwarz / black						17 - 22 - schwarz / black			
			22 - 27 - blau / blue						22 - 27 - blau / blue			
✉	DB50	ø28	8 - 12 - elfenbein / ivory	36	36	✉	DB65	ø32	8 - 12 - elfenbein / ivory	M24	M24	30
			12 - 17 - grau / grey						12 - 17 - grau / grey			
			17 - 22 - schwarz / black						17 - 22 - schwarz / black			
✉	DB50	ø28	8 - 12 - elfenbein / ivory	36	36	✉	DB65	ø38	8 - 12 - elfenbein / ivory	1 1/4"ww	1 1/4"ww	30
			12 - 17 - grau / grey						12 - 17 - grau / grey			
			17 - 22 - schwarz / black						17 - 22 - schwarz / black			

Montagebeispiel

Installation
procedure

Exemple de montage
sur plancher béton

Ejemplo
de montaje

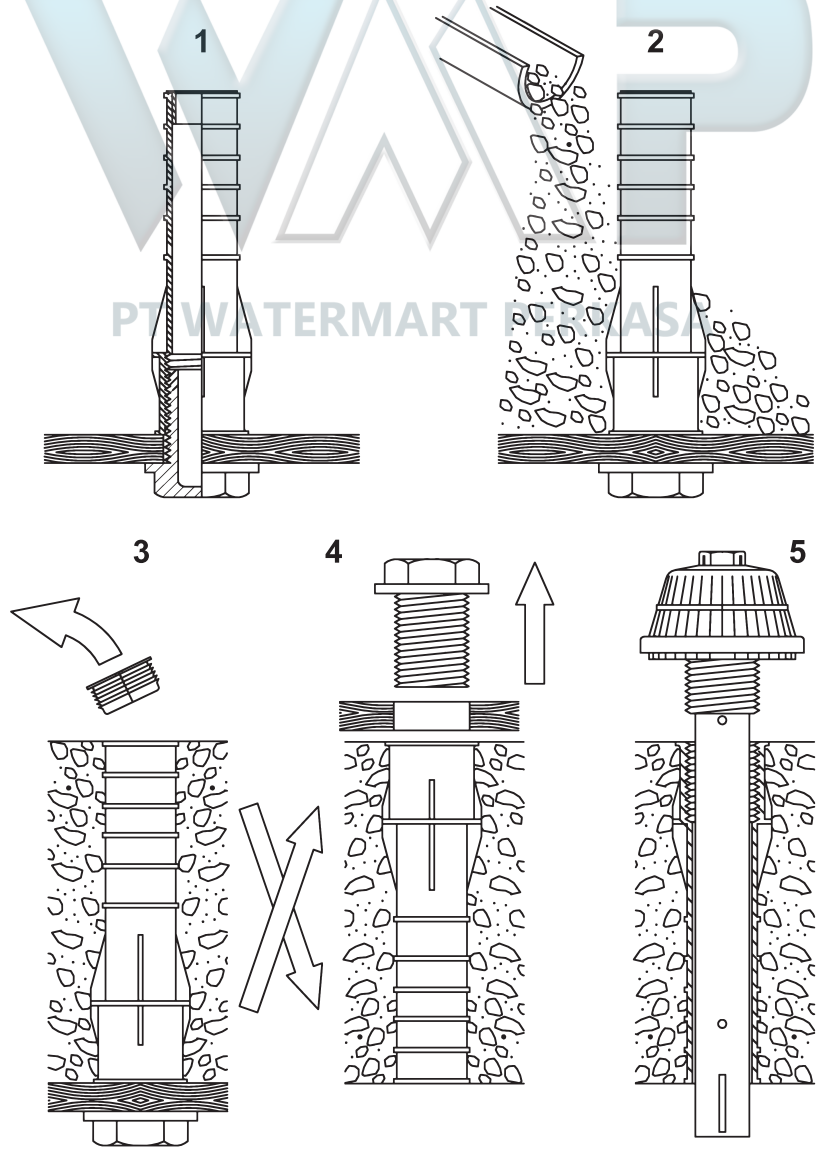
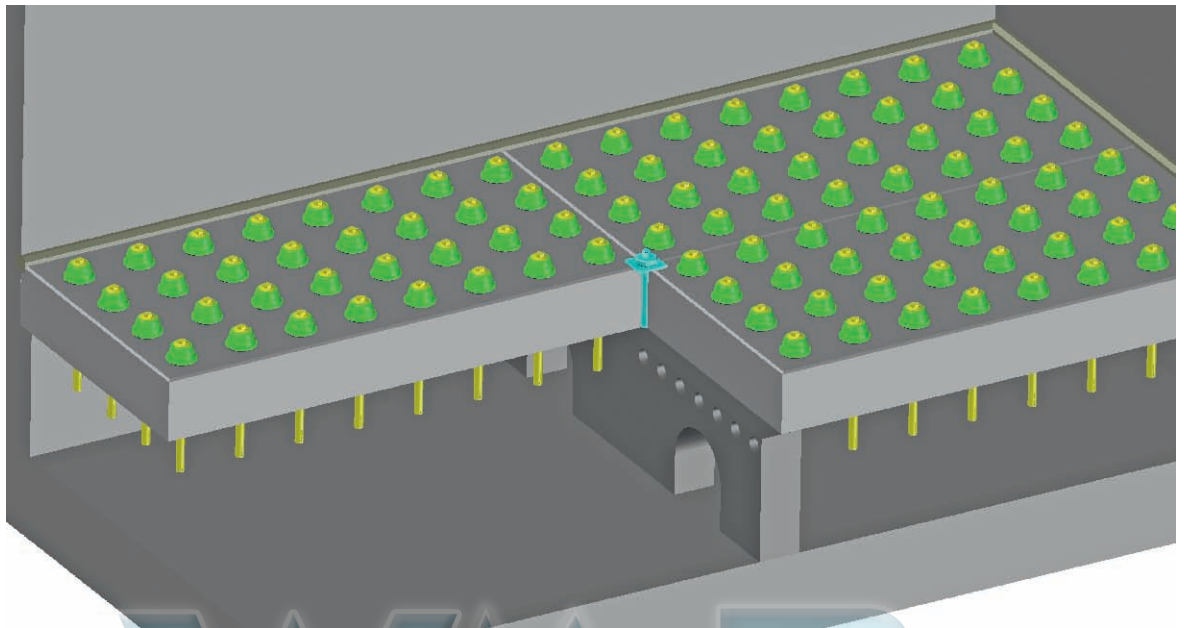

Montagebeispiel
II

Installation
procedure

Exemple de montage
sur plancher beton

Ejemplo
de montaje

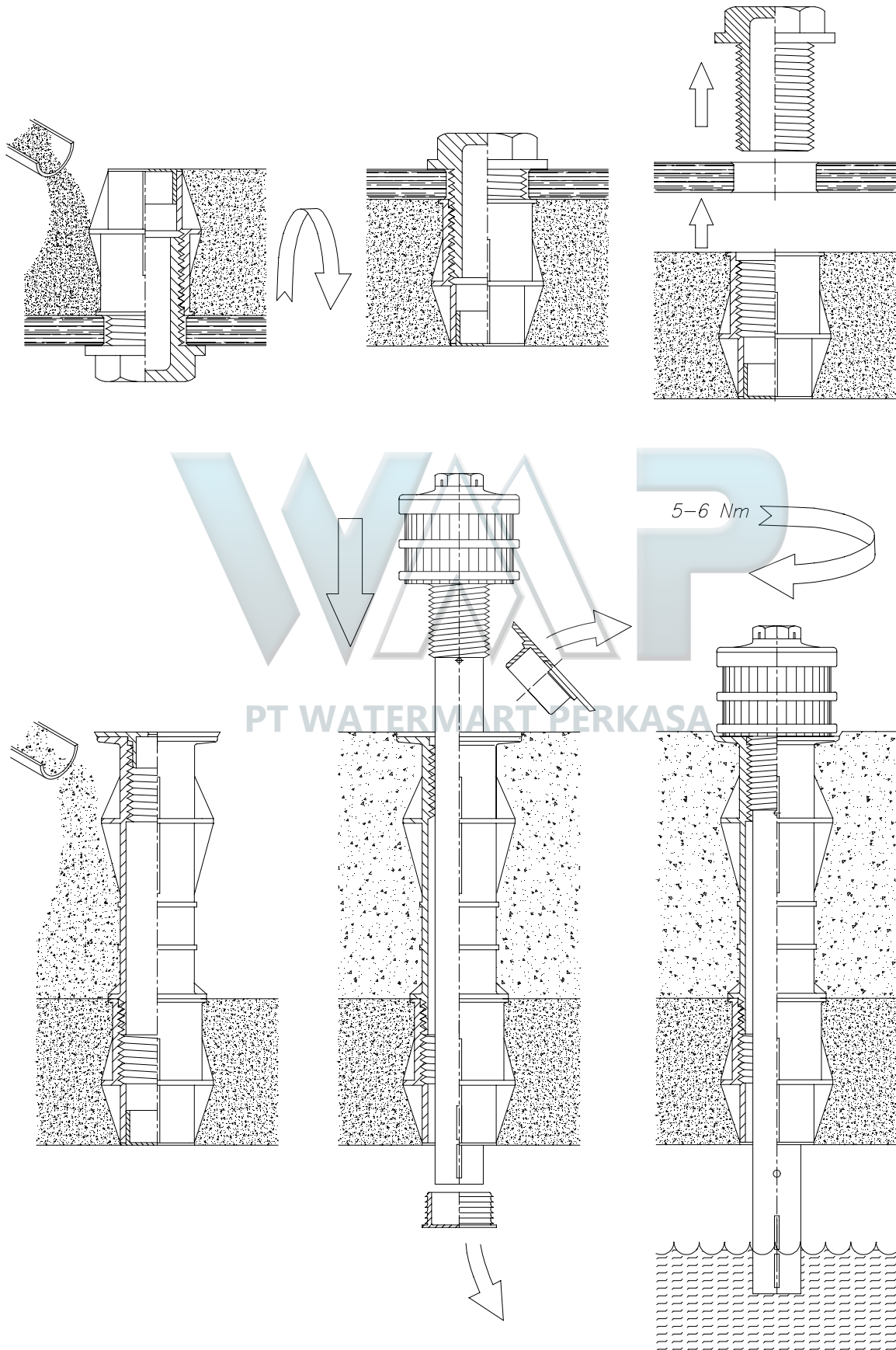

Buchsen für Beton-Filterböden	Sleeves for concrete - floors	Douilles et accessoires pour planchers béton	Casquillos para fondos de filtros de hormigon
--------------------------------------	--------------------------------------	---	--

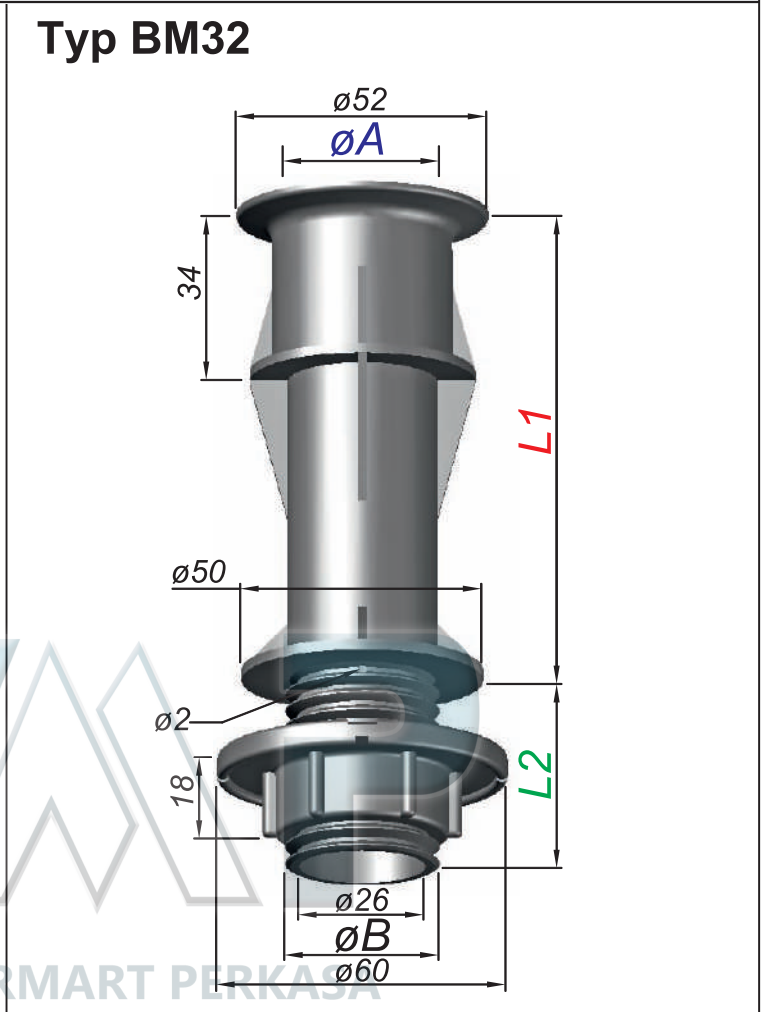
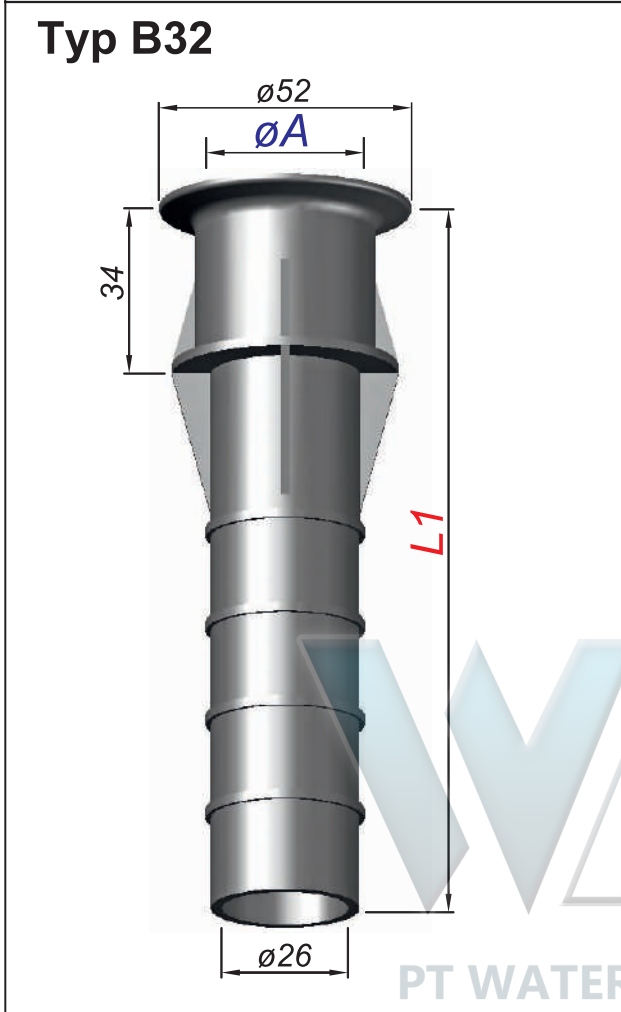

Bestellung Ordering Commande Encargo	Typ Type Type Tipa	Gewinde Thread Filetage Rosca	$\varnothing A$	L1	Bestellung Ordering Commande Encargo	Typ Type Type Tipa	Gewinde Thread Filetage Rosca	$\varnothing A$	$\varnothing B$	L1	L2
	B32	1 1/4"WW 1"WW		60, +10, +10, ... - 500		BM32	1 1/4"WW	1 1/4"WW	60, +10, +10, ... - 500	40	

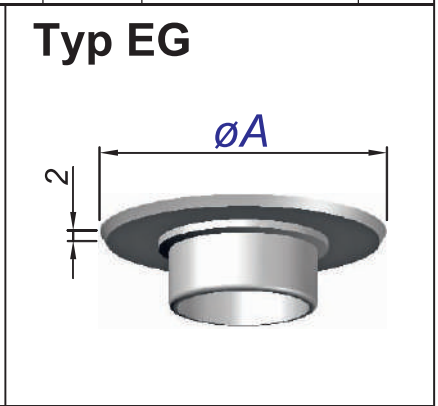
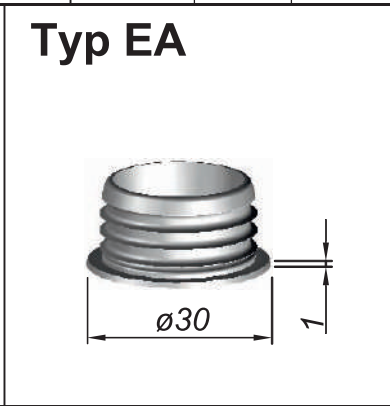
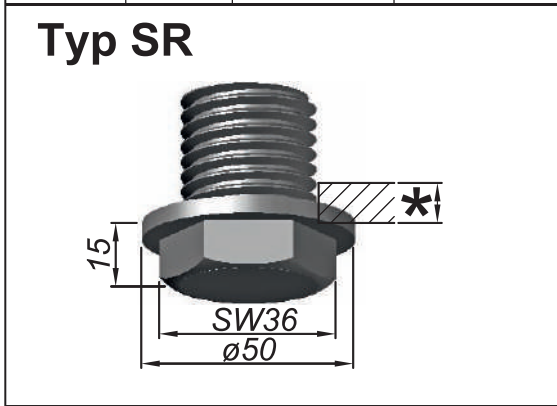

Bestellung Ordering Commande Encargo	Typ Type Type Tipa	Gewinde Thread Filetage Rosca	$\varnothing A$	Bodenstärke plate thickness * Epaisseur du plancher Espesor placa	Bestellung Ordering Commande Encargo	Typ Type Type Tipa		Bestellung Ordering Commande Encargo	Typ Type Type Tipa	$\varnothing A$
	SR	1 1/4"WW 1"WW		= mm		EA			EG50	54
									EG70	71

**Buchsen
für Rohre**

**Special lateral
sleeves**

**douilles pour tuyaux
et planchers béton**

**Casquillos
para tuberia**

Montagebeispiel

Installation
procedure

Exemple
de montage

Ejemplo
de montaje

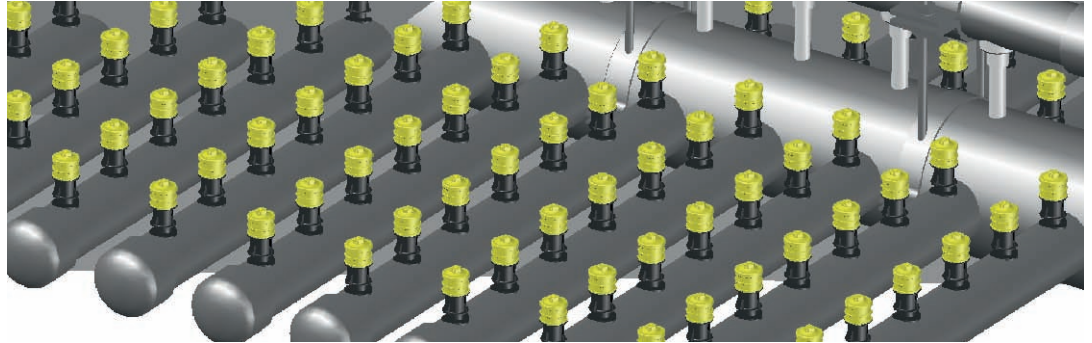

Typ BR32

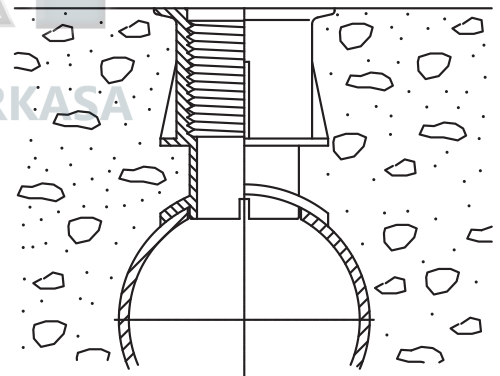
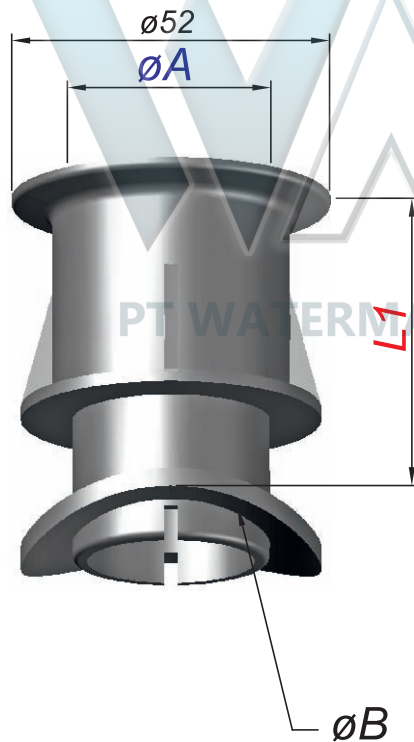

Bestellung Ordering Commande Encargo	Typ Type Type Tipa	L1	$\varnothing B$	Gewinde Thread Filetage Rosca	$\varnothing A$
	BR32	15	90; 110	1 1/4"WW	
		50	75; 90; 110; 324		

Anschluß-
armatur

Manifold
head

Raccord pour
bouteilles
échangeuses d'ions

Racor Adaptador
para Botellas de
intercambio Ionico

Typ ANA2



P max. 8 bar – 120 PSI

T max. 45°C – 110° F

Typ ANA2

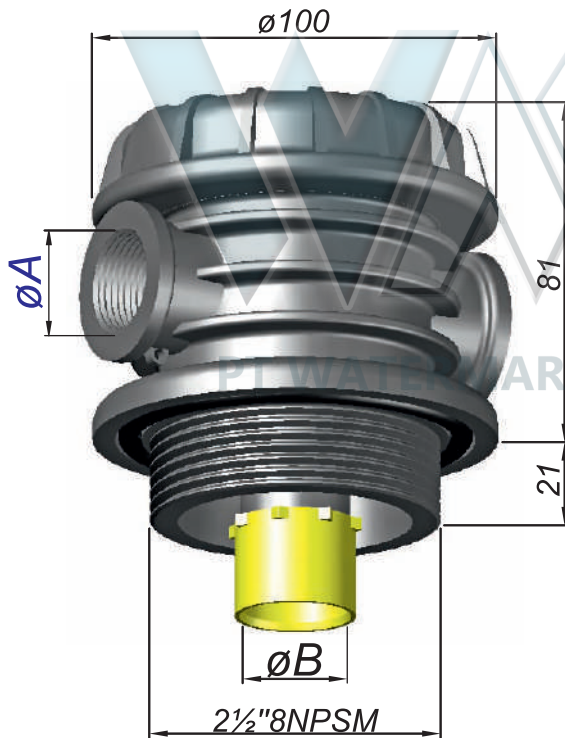

Bestellung Ordering Commande Encargo	Typ Type Type Tipa	øA	øB = mm	
✉	ANA2	1/4"NPT	1"	Ø 25,4
		G 3/4"	13/16	Ø 20,64
			1,05"	Ø 26,67
		3/4"NPT	25	Ø 25,2

Typ ANA-S



Bestellung Ordering Commande Encargo	Typ Type Type Tipa
✉	ANA-S

Typ ANA-K

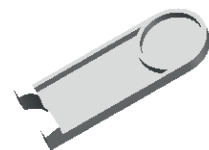

Bestellung Ordering Commande Encargo	Typ Type Type Tipa
✉	ANA-K

Anschluß- armatur	Manifold head	Raccord pour bouteilles échangeuses d'ions	Racor Adaptador para Botellas de intercambio Ionico
------------------------------	--------------------------	---	--

Typ ANA2-QD



P max. 8 bar – 120 PSI
T max. 45°C – 110° F

Typ ANA2-QD

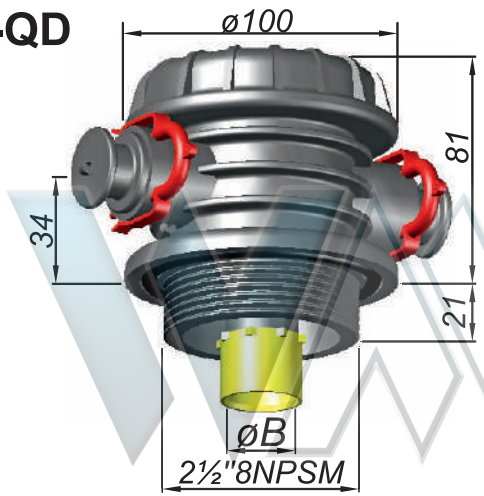

Bestellung Ordering Commande Encargo	Typ Type Type Tipa		ØB = mm
✉	ANA2-QD	1"	Ø 25,4
		13/16	Ø 20,64
		1,05"	Ø 26,67
		25	Ø 25,2

Typ QD-G3/4"

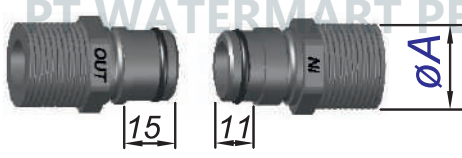

Bestellung Ordering Commande Encargo	Typ Type Type Tipa		
✉	QD-G3/4"		

Typ QDHE

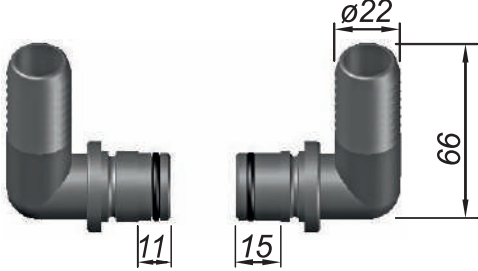

Bestellung Ordering Commande Encargo	Typ Type Type Tipa		
✉	QDHE		

Typ ANA-S



Bestellung Ordering Commande Encargo	Typ Type Type Tipa		
✉	ANA-S		

Typ ANA-K

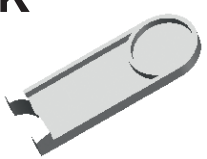

Bestellung Ordering Commande Encargo	Typ Type Type Tipa		
✉	ANA-K		

Anschluß-
armatur

Manifold
head

Raccord pour
bouteilles
échangeuses d'ions

Racor Adaptador
para Botellas de
intercambio Ionico

Typ ANA3

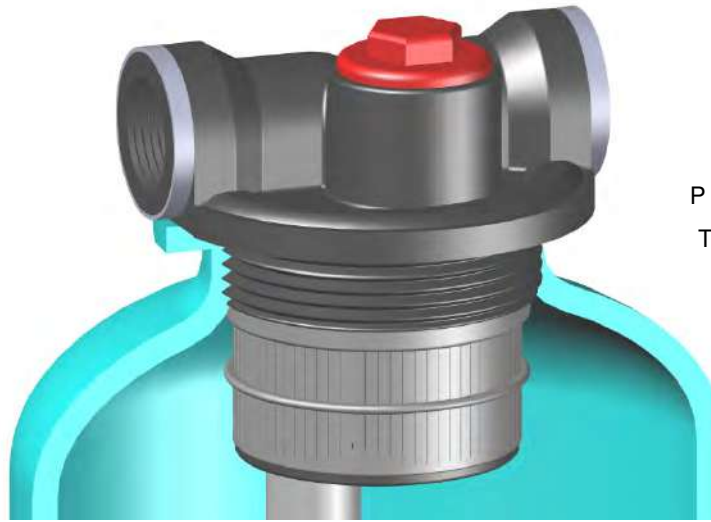

P max. 8 bar – 120 PSI

T max. 45°C – 110°F

Typ ANA3

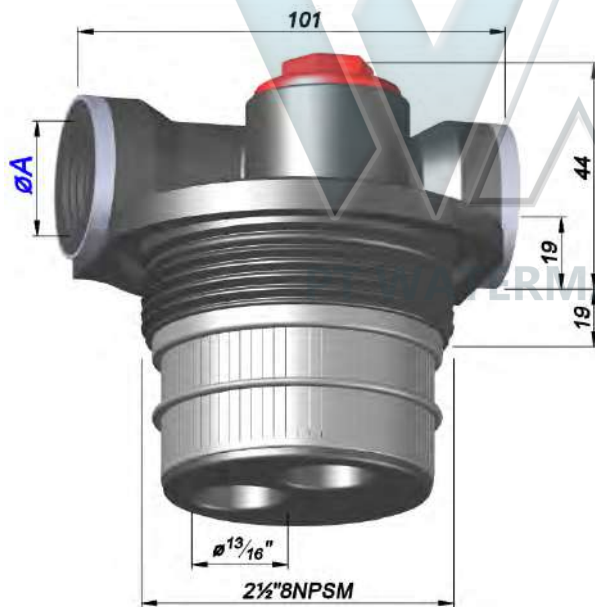

Typ RA-L

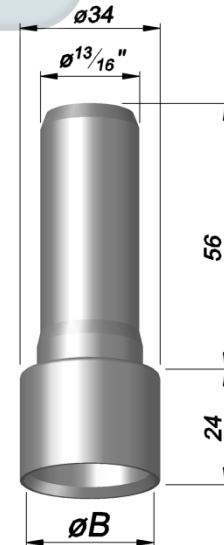

Bestellung Ordering Commande Encargo	Typ Type Type Tipa	ØA	Schlitze Slots Fentes Ranuras
	ANA3	G 3/4" 3/4"NPT	0,2 0,3 0,5

Bestellung Ordering Commande Encargo	Typ Type Type Tipa	ØB = mm
	RA-L	25 Ø 25,2

Filterdüsen- für Düsenstab	Filter-Nozzles for Distributor	Crépines pour distributeur	Toberas de distribucion
-------------------------------	-----------------------------------	-------------------------------	----------------------------

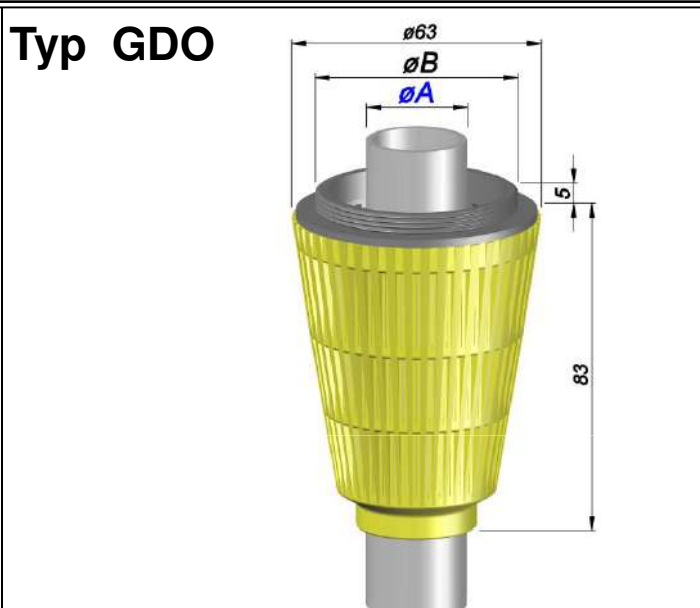
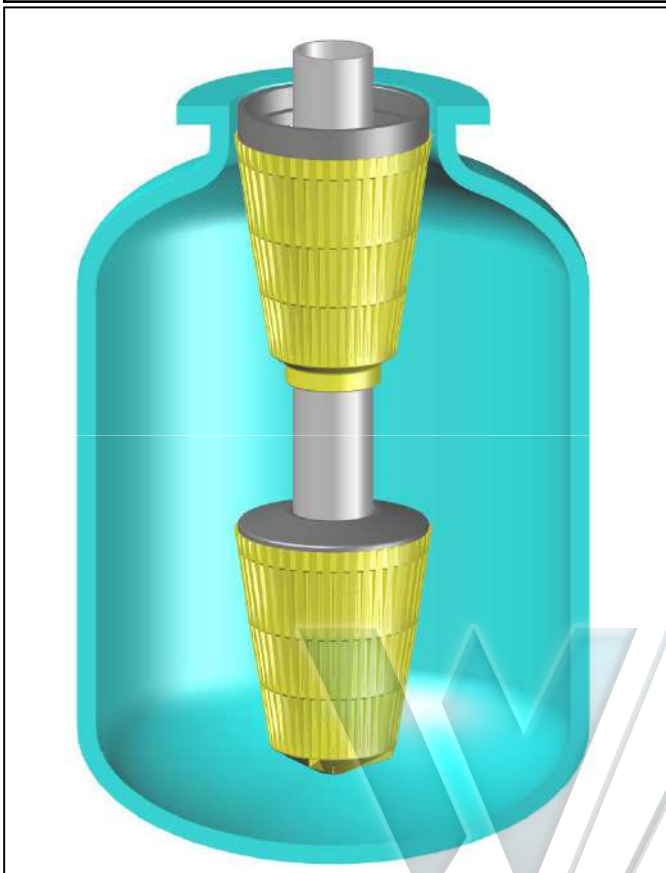

Bestellung Ordering Commande Encargo	Typ Type Type Tipa	Schlitze Slots Fentes Ranuras	$\varnothing B$	$\varnothing A$	=mm
✉	GDO	0,2 = 5,22cm ²	2"20	32	Ø 32
			Ø 60,5	13/16	Ø 20,64
			Ø 60	1"	Ø 25,4
			QD	1,05"	Ø 26,67
				25	Ø 25,2



Bestellung Ordering Commande Encargo	Typ Type Type Tipa	Schlitze Slots Fentes Ranuras	$\varnothing A$	=mm
✉	GDUK	0,2 = 5,22cm ²	1"	Ø 25,4
			13/16	Ø 20,64
			1,05"	Ø 26,67
			25	Ø 25,2
			1/2"	Ø 21,4

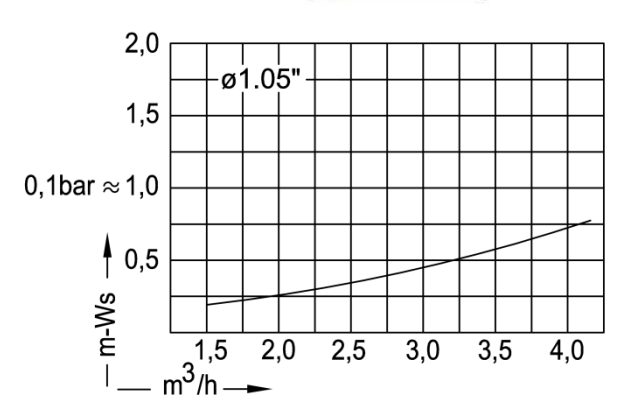

**Filterdüsen-
für Düsenstab**

**Filter-Nozzles
for Distributor**

**Crépines pour
distributeur**

**Toberas
de distribucion**

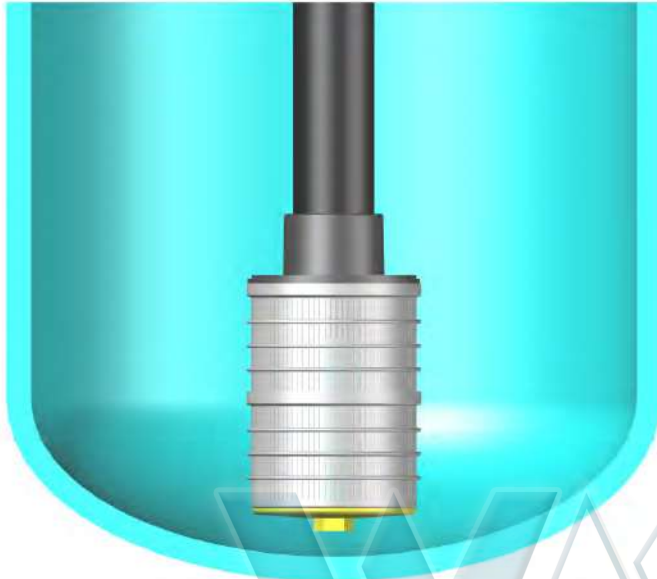

Bestellung Ordering Commande Encargo	Typ Type Type Tipa	Schlitze Slots Fentes Ranuras	ϕA
	GLU	0,2 0,3 0,5	3/4"NPT ϕ 24,4

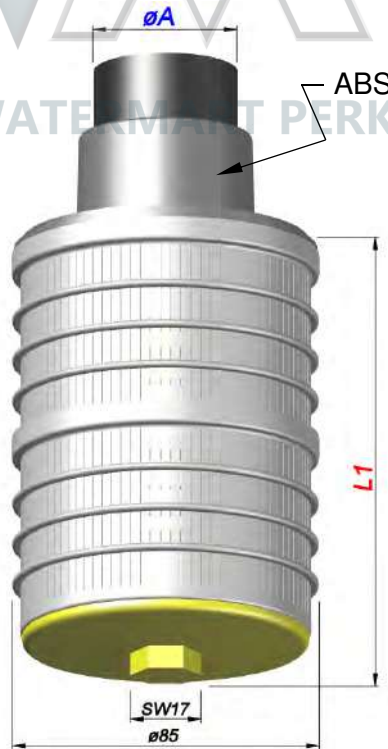
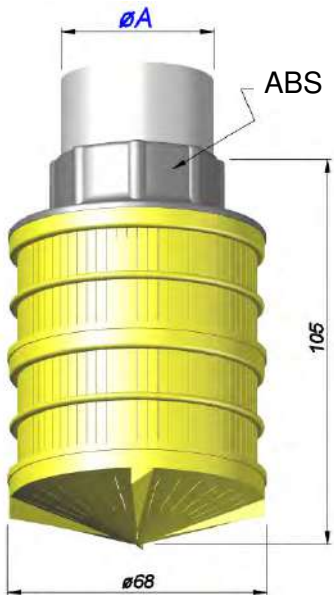

Bestellung Ordering Commande Encargo	Typ Type Type Tipa	Schlitze Slots Fentes Ranuras	ϕA	Bestellung Ordering Commande Encargo	Typ Type Type Tipa	Schlitze Slots Fentes Ranuras	ϕA	Länge Length Longueur Largura	$L1$	Bestellung Ordering Commande Encargo	Typ Type Type Tipa	Schlitze Slots Fentes Ranuras	ϕA
	GWU	0,2 = 6,91 cm ²	$\phi 32$ $\phi 40$		GRU	0,2	ϕ 40 ϕ 50 ϕ 63	73 ; 126		GCU	0,2	3/4"NPT ϕ 24,4	
		0,3 = 11,03 cm ²				0,5					0,3		
		0,5 = 17,94 cm ²									0,5		

Entleerungs- Entnahme-Filterdüsen	Drain- Nozzles	Crépines de drainage	Toberas de drenaje
--------------------------------------	-------------------	-------------------------	-----------------------

Montagebeispiel

Installation
procedure

Exemple
de montage

Ejemplo
de montaje



Typ EDK

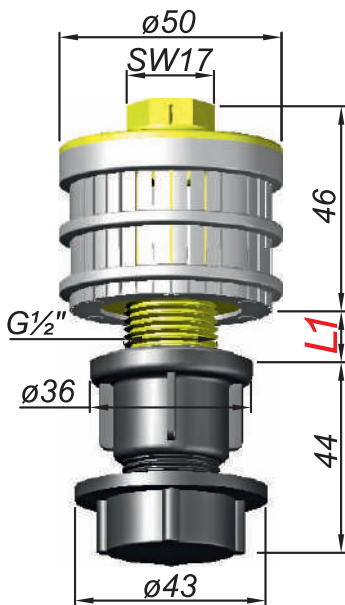

Typ ED

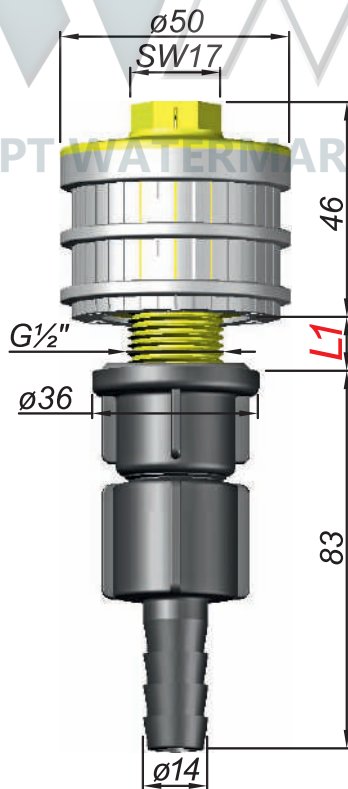

Typ EHK

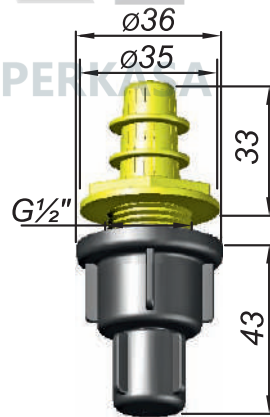

Typ EH

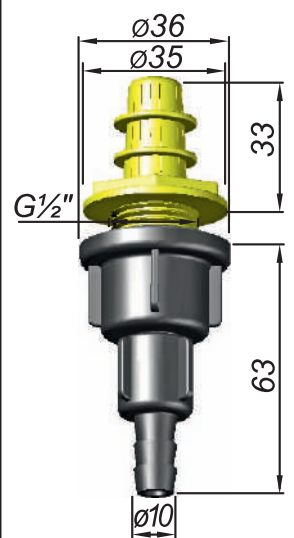

Bestellung Ordering Commande Encargo	Typ Type Type Tipa	Schlitze Slots Fentes Ranuras	Bodenstärke Plate thickness Epaisseur du plancher Espesor placa	Bestellung Ordering Commande Encargo	Typ Type Type Tipa	Bestellung Ordering Commande Encargo	Typ Type Type Tipa
	ED EDK	36 x 0,2 = 1,37 cm ² 36 x 0,5 = 3,42 cm ²	Nach Angabe according detail selon détails adecuado detalle		EHK-0,2		EH-0,2

**Entleerungs-
Entnahme-Filterdüsen**

**Drain-
Nozzles**

**Crépines
de drainage**

**Toberas
de drenaje**

Typ E

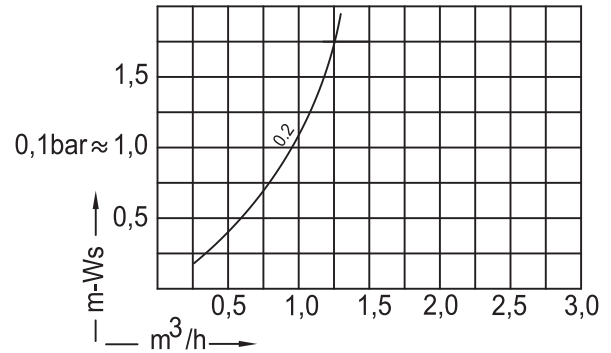
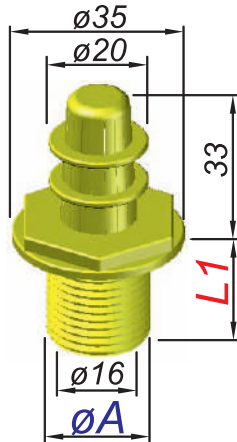

Bestellung Ordering Commande Encargo	Typ Type Type Tipa	Schlitz Slots Fentes Ranuras	Gewinde Thread Filetage Rosca	Gewindelänge Thread length Longueur de filetage Largura de la rosca
	E	0,2 = 1,0cm ²	G 1/2"	8
			G 3/4"	17

Typ E2

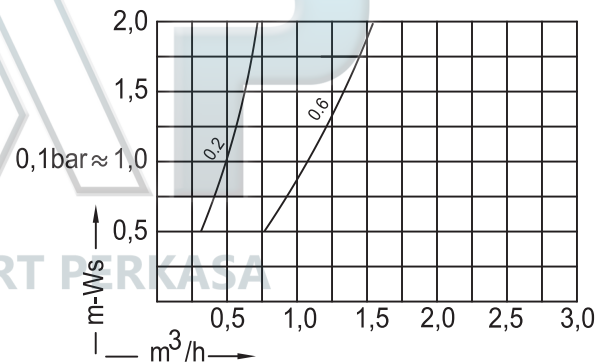
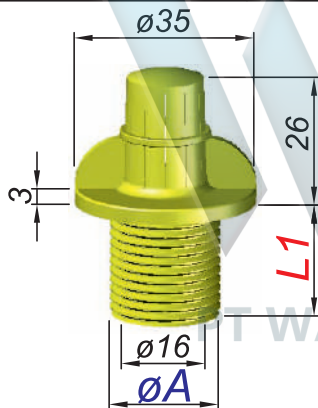

Bestellung Ordering Commande Encargo	Typ Type Type Tipa	Schlitz Slots Fentes Ranuras	Gewinde Thread Filetage Rosca	Gewindelänge Thread length Longueur de filetage Largura de la rosca
	E2	0,2 = 0,28cm ²	G 1/2"	22
		0,6 = 0,84cm ²	7/8"WW	16

Typ ES10

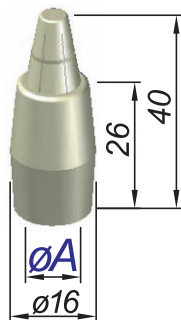

Bestellung Ordering Commande Encargo	Typ Type Type Tipa	Schlitz Slots Fentes Ranuras	øA
	ES10	0,2	6
			8
			10

Verteiler

distributor

Distributeur

Distribuidor

Montagebeispiel

Installation procedure

Exemple de montage

Ejemplo de montaje



Typ OV

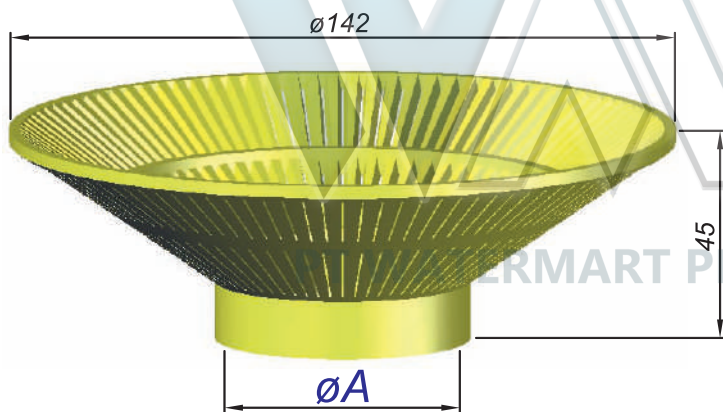

Bestellung Ordering Commande Encargo	Typ Type Type Tipa	Schlitze Slots Fentes Ranuras	$\varnothing A$
	OV	0,25	$\varnothing 1,9''$ $\varnothing 50$

Typ UV

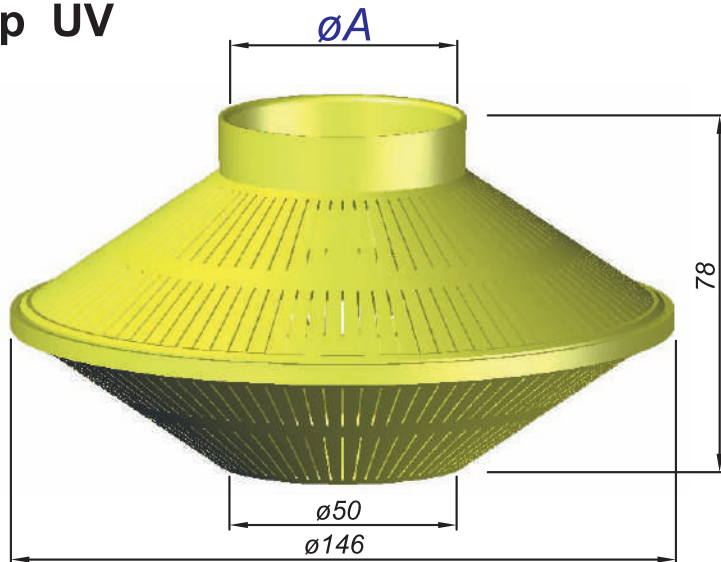

Bestellung Ordering Commande Encargo	Typ Type Type Tipa	Schlitze Slots Fentes Ranuras	$\varnothing A$
	UV	0,25 = 17,96 cm ²	$\varnothing 1,9''$ $\varnothing 50$

Obere Verteiler

Top distributor

Distributeur supérieur

Distribuidor superior

R2P

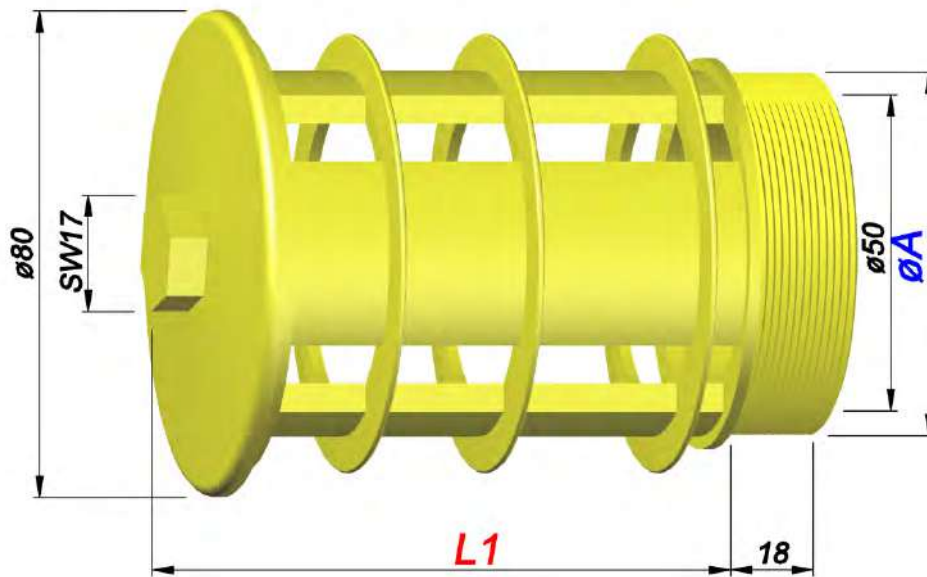

Bestellung Ordering Commande Encargo	Typ Type Type Tipa	Gewinde Thread Filetage Rosca	Gewindelänge Thread length Longueur de filetage Largura de la rosca
	R2P	G 2"	42, 95, 155

R3P

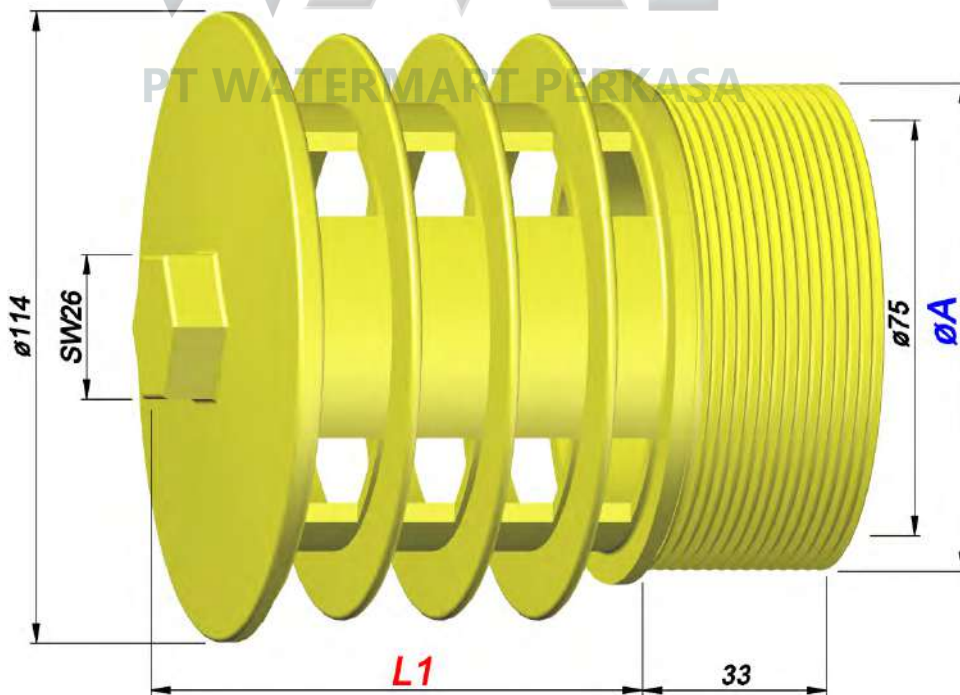

Bestellung Ordering Commande Encargo	Typ Type Type Tipa	Gewinde Thread Filetage Rosca	Länge Length Longueur Largura
	R3P	G 3" 3" NPT 4" 8UN	96, 168, 240

Filterdüsen

Filter-Nozzles

Crépines à filtre

Toberas filtrantes

Typ R2

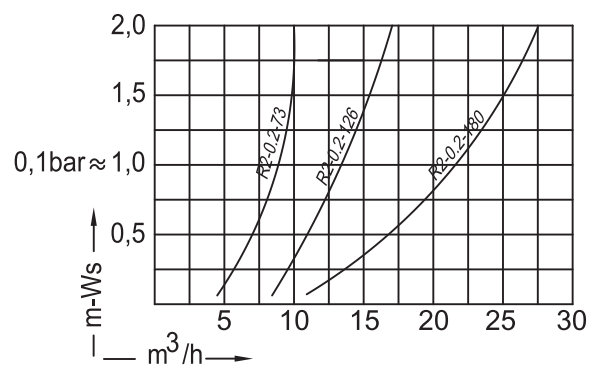
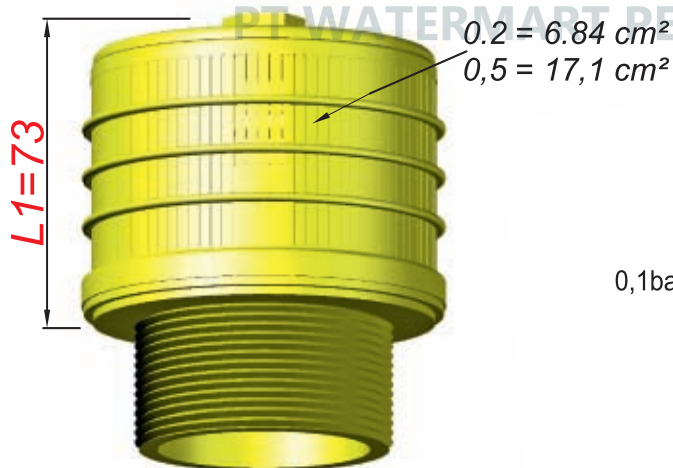
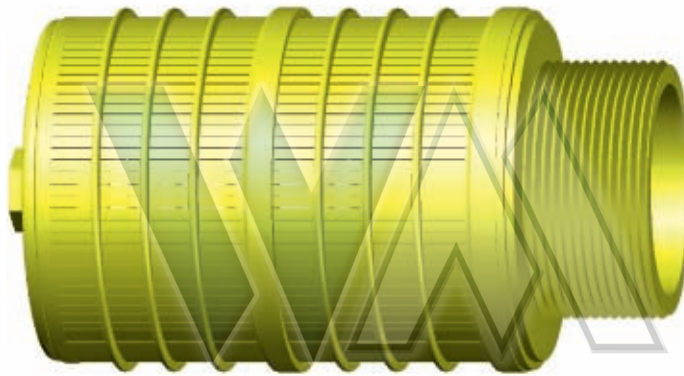
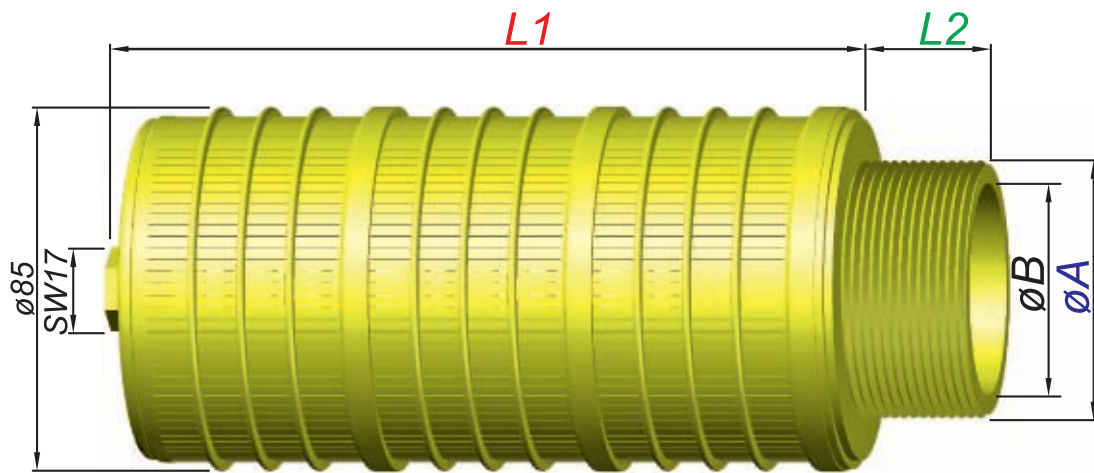

Bestellung Ordering Commande Encargo	Typ Type Type Tipa	Schlitze Slots Fentes Ranuras	$\varnothing A$	$\varnothing B$	$L2$	Kopflänge Headlength Longueur de tête Longitude de la cabeza
	R2	0,2	G 2"	$\varnothing 50$	30, 55	$L1$ 73, 126, 180, 231, 284, 338, 389, 442, 496, 547, 600, 654, 705, 758, 812, 863, 916, 970, 1021, 1074, 1128, 1179, 1232, 1286
		0,3	G 1½"	$\varnothing 38$	30, 55	
		0,5	G 2"	1 1/4"NPT	30	
		1,0	G 2"	1 1/2"NPT	30	
			$\varnothing 68$	G 2"	30	
			1 1/2"NPT	1 1/4"NPT	30	
			2 ½" 8NPSM	$\varnothing 60$	20	

Typ R3

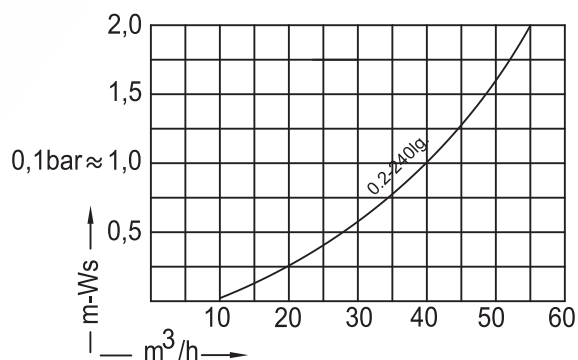
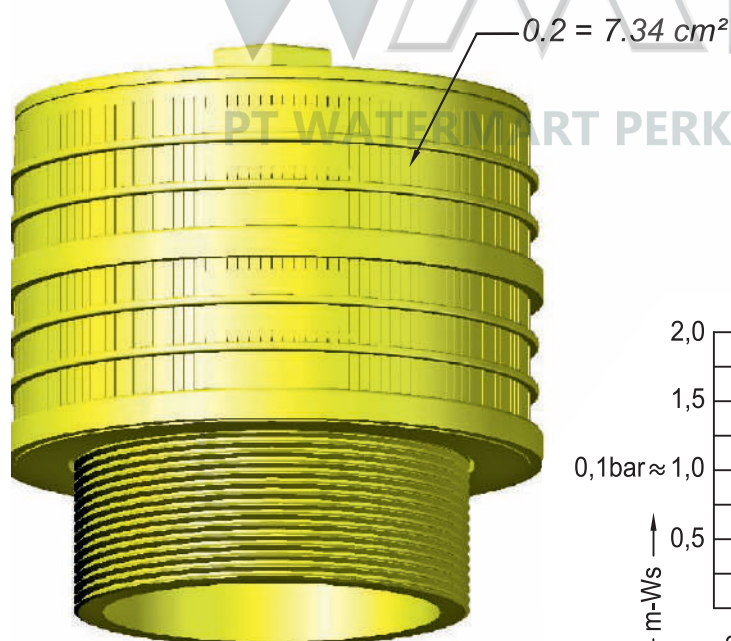
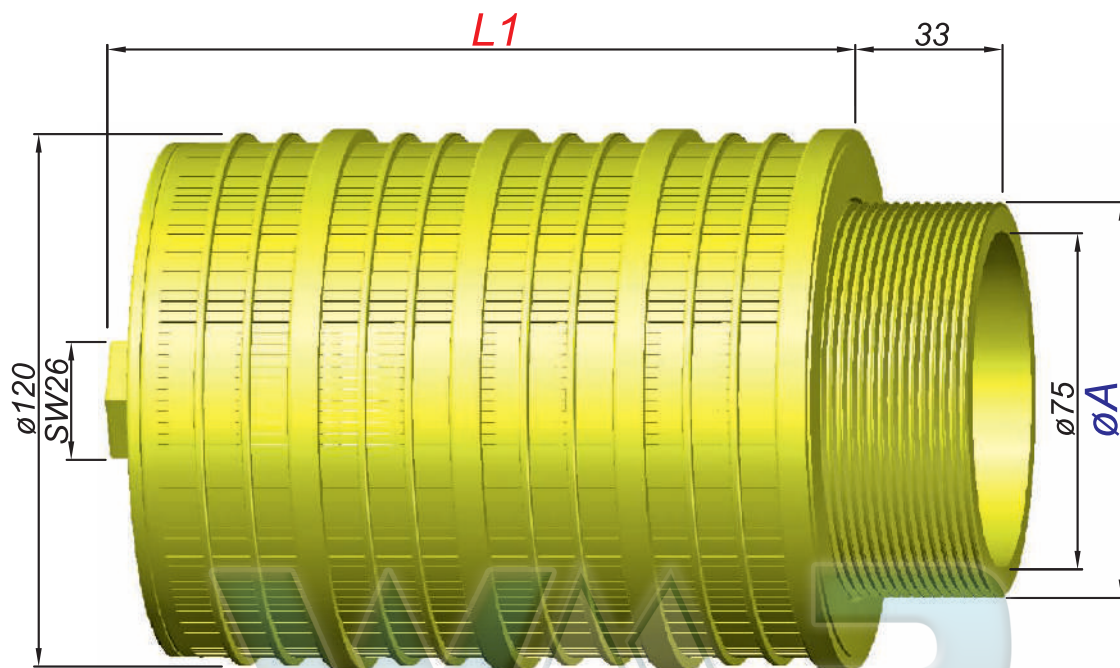

Bestellung Ordering Commande Encargo	Typ Type Type Tipa	Schlitze Slots Fentes Ranuras	øA	Kopflänge Headlength Longueur de tête Longitude de la cabeza
	R3	0,2 0,5	G 3" 3"NPT 4" 8UN	L1 168, 240, 312, 384, 456, 528, 600, 672, 744, 816, 888, 960, 1032, 1104, 1176, 1248, 1320 ...

Anfahrentlüfter und
Vacuumbrecher
(Belüfter)

Aeration
valve

Valve
d'aeration

Vavula
de Venteo

Typ BEL

P max. 10 bar
t max. 65°C

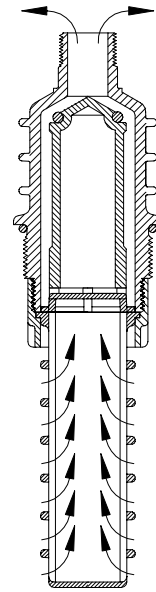
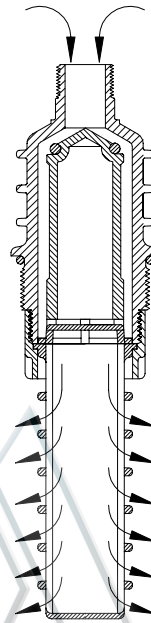
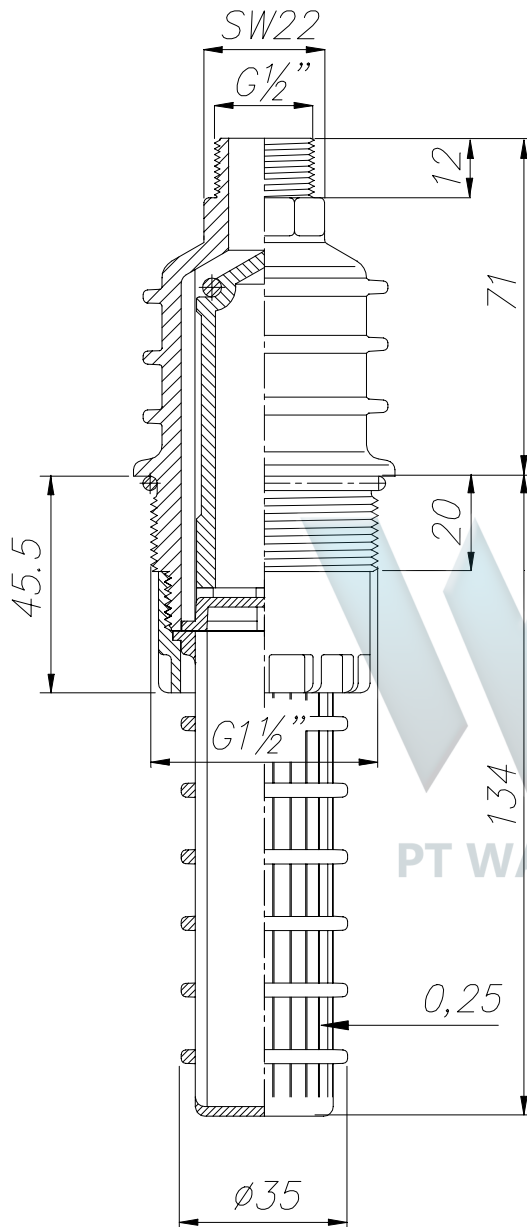

PT WATERMART PERKASA

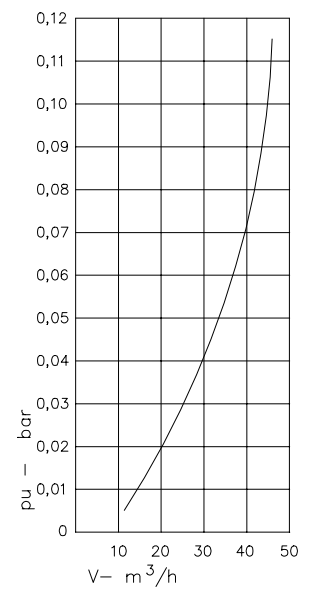
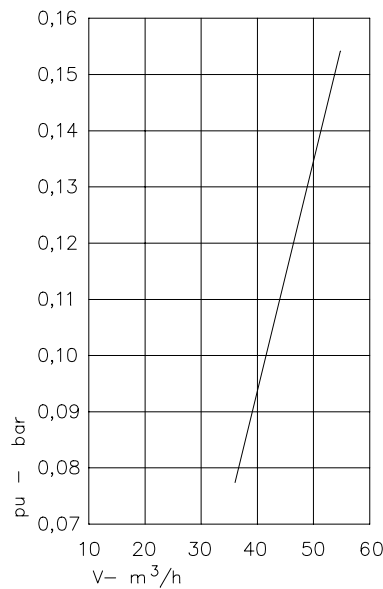

Bestellung Ordering Commande Encargo	Typ Type Type Tipa	Material Material Materiau Material

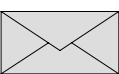

BEL

**PP GV30S
PVDF**

**Filterdüsen-
Arme**

**Filter-Nozzles
Arms**

Crépines bras

**Brazos de toberas
a filtro**

Typ A

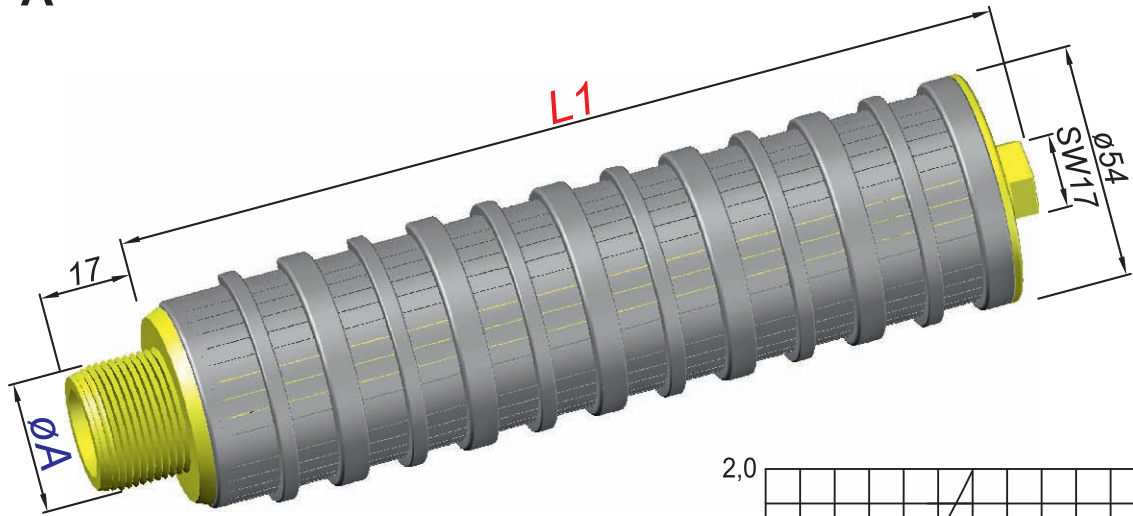

Bestellung Ordering Commande Encargo	Typ Type Type Tipa	Schlitze Slots Fentes Ranuras	Gewinde Thread Filetage Rosca	$\varnothing A$
	A	0,2 0,5 1,0 2,0	M30x2 3/4"NPT G 3/4" G 1"	

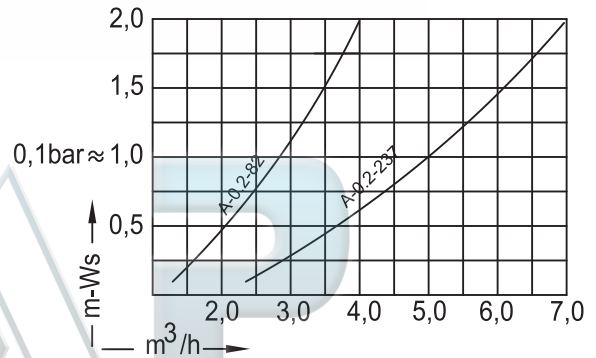

A	SG6	SK6	SO6	SO8	SK8	SK6F	SK8F
Länge Length Longueur Largura	L1						
	∅ = mm						
82	259	258	258				
113	321	316	316				
144	383	374	374				
175	445	432	432				
206	507	491	491	520	520	491	520
237	569	549	549	580	580	549	580
268	631	607	607	640	640	607	640
299	693	665	665	699	699	665	699
330	755	724	724	759	759	724	759
361	817	782	782	819	819	782	819
392	879	840	840	879	879	840	879
423	941	898	898	939	939	898	939
454	1003	957	957	999	999	957	999
485	1065	1015	1015	1059	1059	1015	1059
516	1127	1073	1073	1119	1119	1073	1119
547	1189	1131	1131	1179	1179	1131	1179
578	1251	1189	1189	1239	1239	1189	1239
609	1313	1247	1247	1299	1299	1247	1299
640				1359	1359	1305	1359
671				1419	1419	1363	1419
702				1479	1479	1421	1479
733				1539	1539	1479	1539
764				1599	1599	1537	1599
795				1659	1659	1595	1659

Filterdüsen-Sterne
mit 5 Armen

Filter-Nozzles-Stars
with 5 arms

Crepines etoiles
avec 5 bras

Estrellas para
toberas a filtro
con 5 brazos

Typ SK5

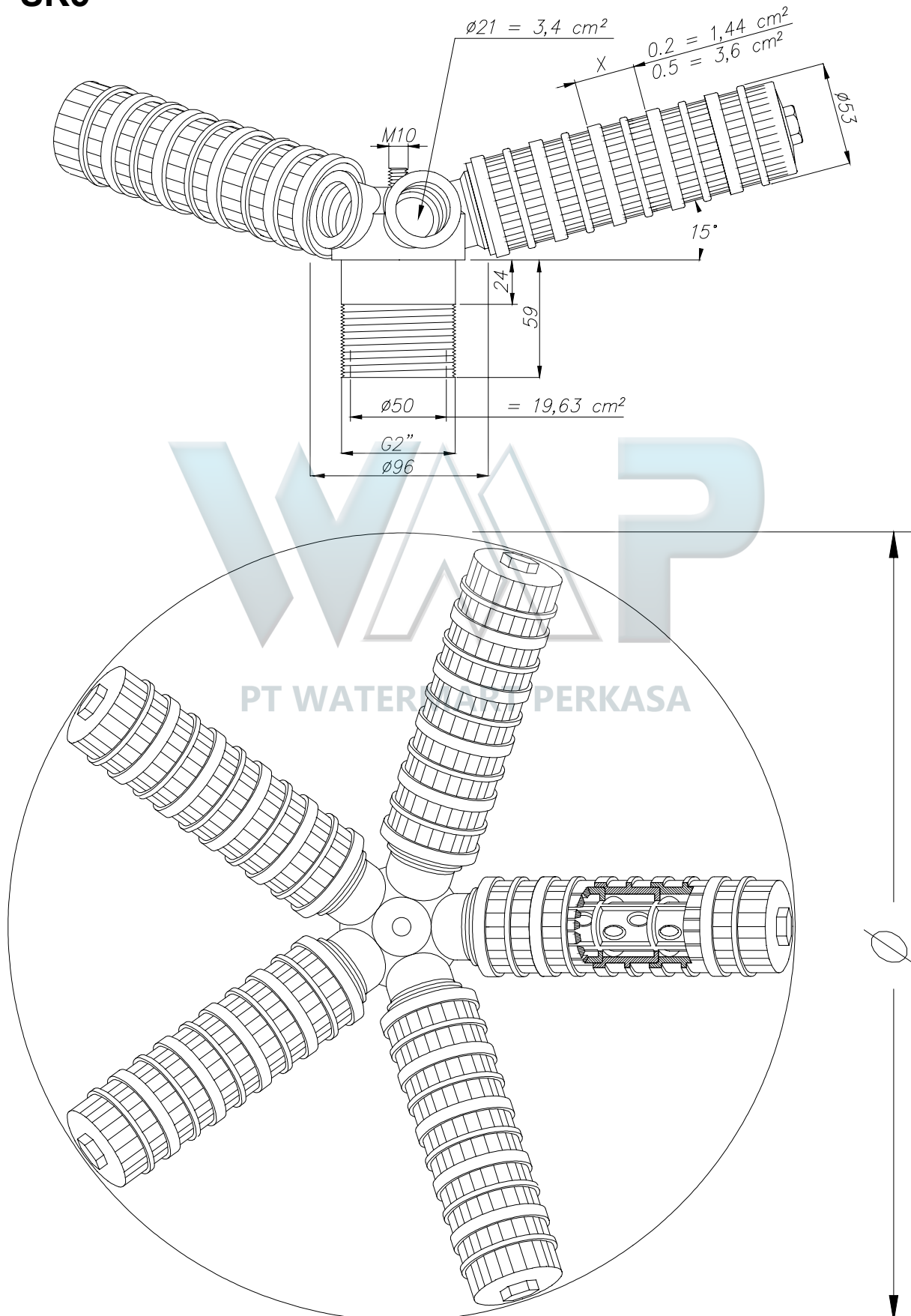

Filterdüsen-Sterne mit 5 Armen

Filter-Nozzles-Stars with 5 arms

Crepines etoiles avec 5 bras

Estrellas para toberas a filtro con 5 brazos

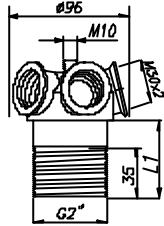

Bestellung Ordering Commande Encargo	Typ Type Type Tipa	L1
	MSK5	59

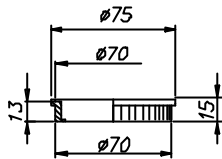

Bestellung Ordering Commande Encargo	Typ Type Type Tipa	Schlitz Slots Fentes Ranuras
	ER	0,2

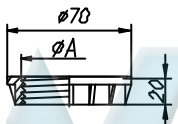

Bestellung Ordering Commande Encargo	Typ Type Type Tipa	Gewinde Thread Filetage Rosca	$\varnothing A$
	MU2	G 1 1/4" G 1 1/2" G 2"	

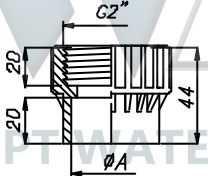

Bestellung Ordering Commande Encargo	Typ Type Type Tipa	$\varnothing A$	Material Material Materiau Material
	GR2	40 50 60,3 63	PVC

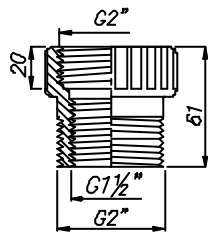

Bestellung Ordering Commande Encargo	Typ Type Type Tipa	Gewinde Thread Filetage Rosca
	GR2	G 1 1/2"

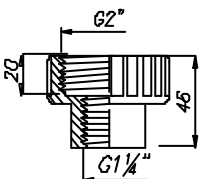

Bestellung Ordering Commande Encargo	Typ Type Type Tipa	Gewinde Thread Filetage Rosca
	GR2	G 1 1/4"

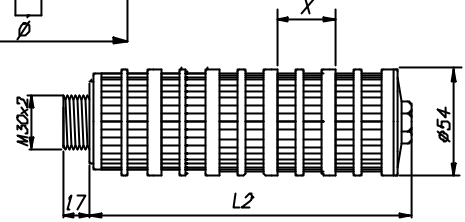
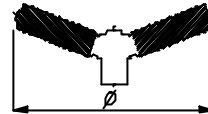

Bestellung Ordering Commande Encargo	Typ Type Type Tipa	Schlitz Slots Fentes Ranuras	X	L2	= \varnothing mm
	A	0,2 / 0,5	2 x	82	= \varnothing 249
		0,2 / 0,5	3 x	113	= \varnothing 309
		0,2 / 0,5	4 x	144	= \varnothing 369
		0,2 / 0,5	5 x	175	= \varnothing 429
		0,2 / 0,5	6 x	206	= \varnothing 489
		0,2 / 0,5	7 x	237	= \varnothing 549
		0,2 / 0,5	8 x	268	= \varnothing 608
		0,2 / 0,5	9 x	299	= \varnothing 668
		0,2 / 0,5	10 x	330	= \varnothing 728
		0,2 / 0,5	11 x	361	= \varnothing 788
		0,2 / 0,5	12 x	392	= \varnothing 848
		0,2 / 0,5	13 x	423	= \varnothing 908
		0,2 / 0,5	14 x	454	= \varnothing 968
		0,2 / 0,5	15 x	485	= \varnothing 1028
		0,2 / 0,5	16 x	516	= \varnothing 1088
		0,2 / 0,5	17 x	547	= \varnothing 1147
		" / "	↓ +1	↓ +31	

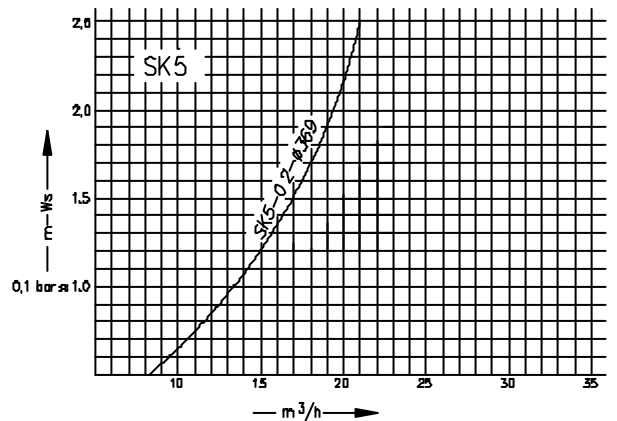

Filterdüsen-Sterne
mit 6 Armen

Filter-Nozzles-Stars
with 6 arms

Crépines
étoiles
à 6 bras

Estrellas para
toberas a filtro
con 6 brazos

Typ SG6

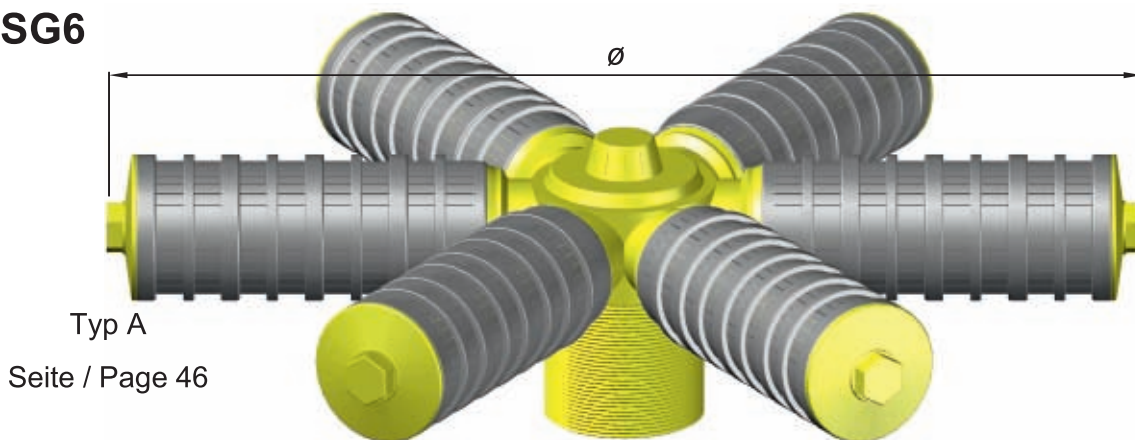

Typ MSG6

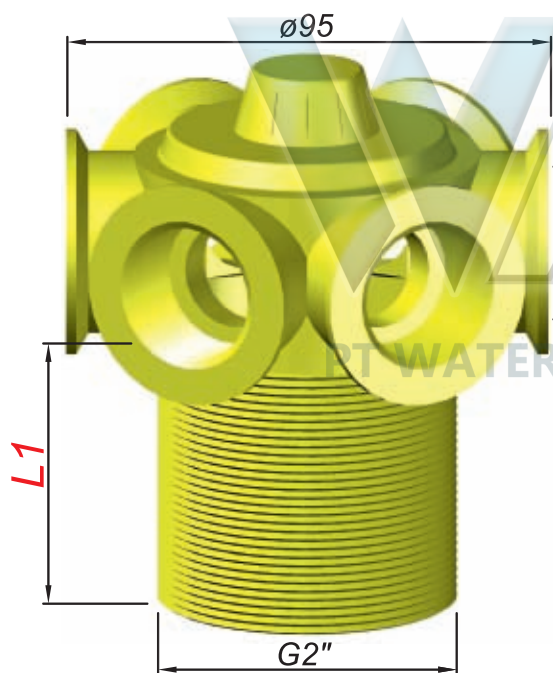

Typ ER

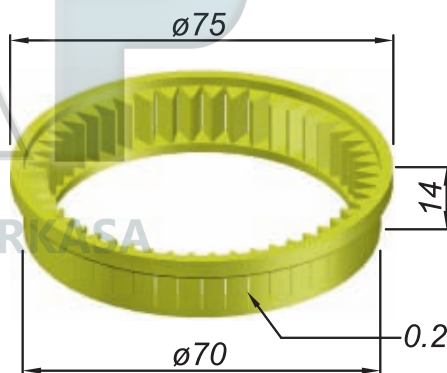

Bestellung Ordering Commande Encargo	Typ Type Type Tipa
	ER

Bestellung Ordering Commande Encargo	Typ Type Type Tipa	L1
	MSG6	25 55

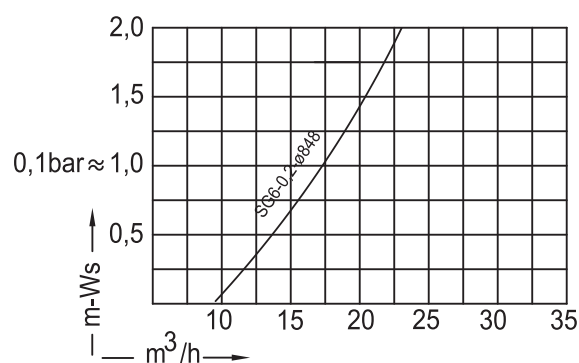

**Filterdüsen-Sterne
mit 6 Armen**



**Filter-Nozzles-Stars
with 6 arms**

**Crepines etoiles
avec 6 bras**

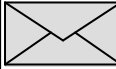

**Estrellas para
toberas a filtro
con 6 brazos**

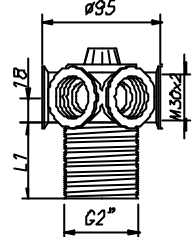



Bestellung Ordering Commande Encargo	Typ Type Type Tipa	L1
	MSG6	25 55

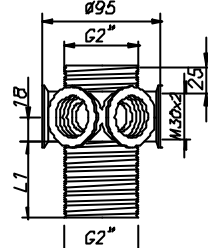



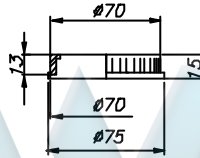

Bestellung Ordering Commande Encargo	Typ Type Type Tipa	L1
	MSG6A	25 55



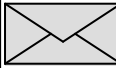

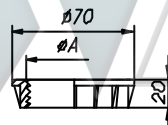

Bestellung Ordering Commande Encargo	Typ Type Type Tipa	Schlitze Slots Fentes Ranuras
	ER	0,2





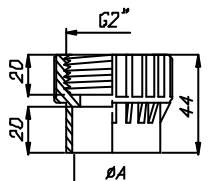

Bestellung Ordering Commande Encargo	Typ Type Type Tipa	Gewinde Thread Filetage Rosca	$\varnothing A$
	MU2"	G 1 1/4" G 1 1/2" G 2"	





Bestellung Ordering Commande Encargo	Typ Type Type Tipa	$\varnothing A$	Material Material Materiau Material
	GR2"	40 50 60,3 63	PVC

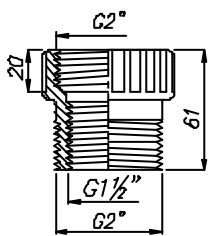



Bestellung Ordering Commande Encargo	Typ Type Type Tipa	Gewinde Thread Filetage Rosca
	GR2"	G 1 1/2"

Bestellung Ordering Commande Encargo	Typ Type Type Tipa	Gewinde Thread Filetage Rosca
	GR2"	G 1 1/4"

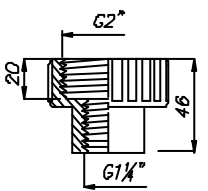
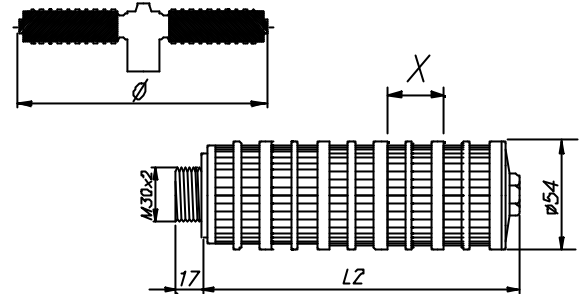
Bestellung Ordering Commande Encargo	Typ Type Type Tipa	Schlitze Slots Fentes Ranuras	X	L2	= \varnothing mm
		0,2 / 0,5	2 x	82	= \varnothing 259
		0,2 / 0,5	3 x	113	= \varnothing 321
		0,2 / 0,5	4 x	144	= \varnothing 383
		0,2 / 0,5	5 x	175	= \varnothing 445
		0,2 / 0,5	6 x	206	= \varnothing 507
		0,2 / 0,5	7 x	237	= \varnothing 569
		0,2 / 0,5	8 x	268	= \varnothing 631
		0,2 / 0,5	9 x	299	= \varnothing 693
		0,2 / 0,5	10 x	330	= \varnothing 755
		0,2 / 0,5	11 x	361	= \varnothing 817
		0,2 / 0,5	12 x	392	= \varnothing 879
		0,2 / 0,5	13 x	423	= \varnothing 941
		0,2 / 0,5	14 x	454	= \varnothing 1003
		0,2 / 0,5	15 x	485	= \varnothing 1065
		0,2 / 0,5	16 x	516	= \varnothing 1127
		0,2 / 0,5	17 x	547	= \varnothing 1189
		" / "	↓ +1	↓ +31	= \varnothing + 62

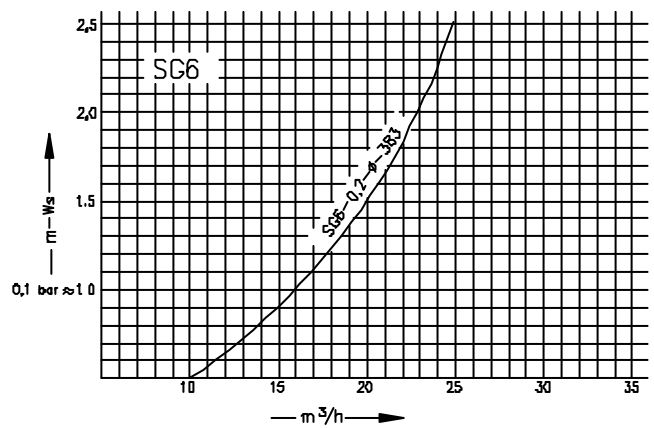

Filterdüsen-Sterne
mit 6 Armen

Filter-Nozzles-Stars
with 6 arms

Crépines
étoiles
à 6 bras

Estrellas para
toberas a filtro
con 6 brazos

Typ SK6

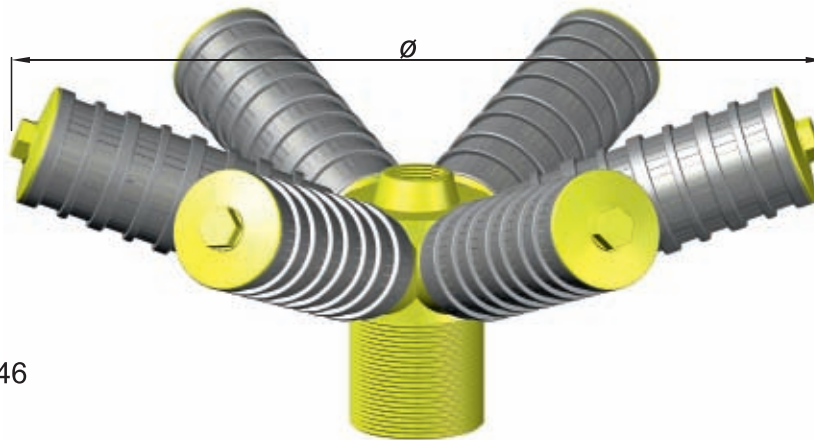

Typ A

Seite / Page 46

Typ MSK6

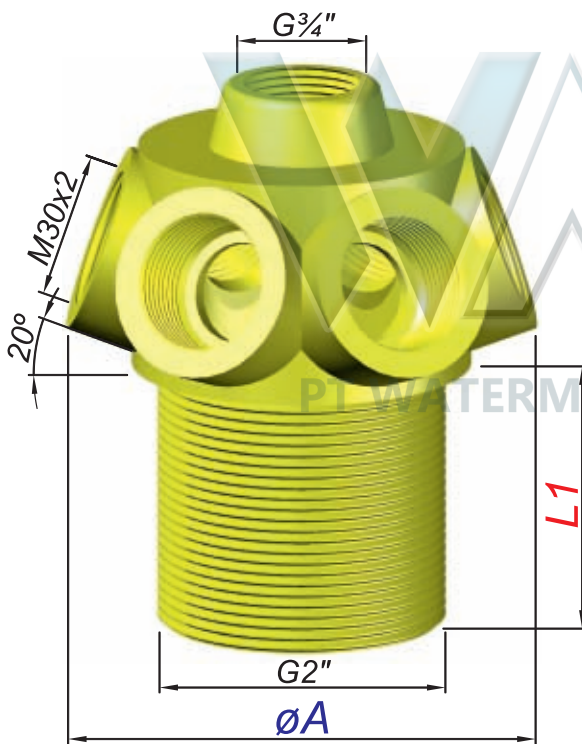

Typ ER

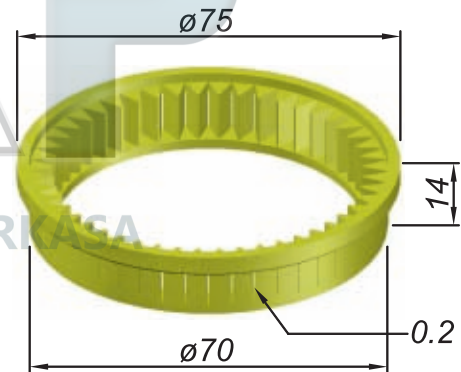

Bestellung Ordering Commande Encargo	Typ Type Type Tipa
	ER

Bestellung Ordering Commande Encargo	Typ Type Type Tipa	L1	$\varnothing A$
	MSK6	55	98 110

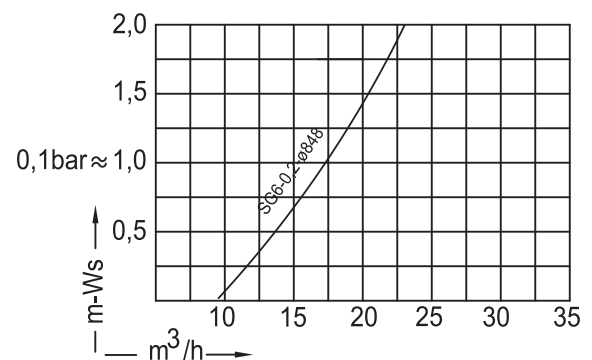

Filterdüsen-Sterne mit 6 Armen

Filter-Nozzles-Stars with 6 arms

Crepines etoiles avec 6 bras



Estrellas para toberas a filtro con 6 brazos

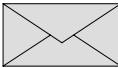

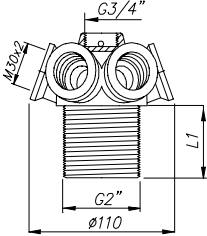
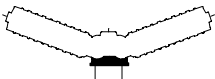

Bestellung Ordering Commande Encargo	Typ Type Type Tipa	L1
	MSK6	25 55

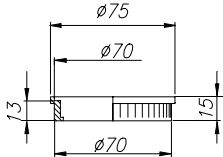



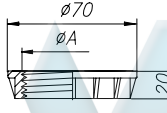

Bestellung Ordering Commande Encargo	Typ Type Type Tipa	Schlitz Slots Fentes Ranuras
	ER	0,2





Bestellung Ordering Commande Encargo	Typ Type Type Tipa	Gewinde Thread Filetage Rosca	øA
	MU2"	G 1 1/4" G 1 1/2" G 2"	

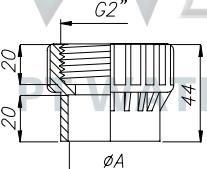
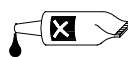



Bestellung Ordering Commande Encargo	Typ Type Type Tipa	øA	Material Material Materiau Material
	GR2"	40 50 60,3 63	PVC



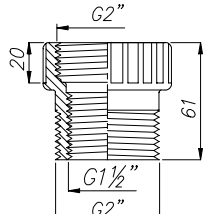
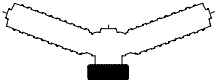

Bestellung Ordering Commande Encargo	Typ Type Type Tipa	Gewinde Thread Filetage Rosca
	GR2"	G 1 1/2"

Bestellung Ordering Commande Encargo	Typ Type Type Tipa	Gewinde Thread Filetage Rosca
	GR2"	G 1 1/4"

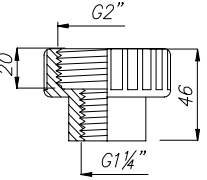
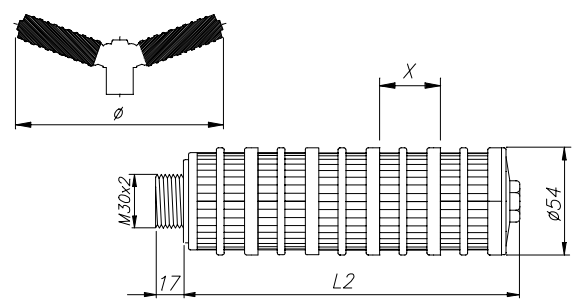
Bestellung Ordering Commande Encargo	Typ Type Type Tipa	Schlitz Slots Fentes Ranuras	X	L2	= Ø mm
		0,2 / 0,5	2 x	82	= Ø 258
		0,2 / 0,5	3 x	113	= Ø 316
		0,2 / 0,5	4 x	144	= Ø 374
		0,2 / 0,5	5 x	175	= Ø 432
		0,2 / 0,5	6 x	206	= Ø 491
		0,2 / 0,5	7 x	237	= Ø 549
		0,2 / 0,5	8 x	268	= Ø 607
		0,2 / 0,5	9 x	299	= Ø 665
		0,2 / 0,5	10 x	330	= Ø 724
		0,2 / 0,5	11 x	361	= Ø 782
		0,2 / 0,5	12 x	392	= Ø 840
		0,2 / 0,5	13 x	423	= Ø 898
		0,2 / 0,5	14 x	454	= Ø 957
		0,2 / 0,5	15 x	485	= Ø 1015
		0,2 / 0,5	16 x	516	= Ø 1073
		0,2 / 0,5	17 x	547	= Ø 1131
		7	↓ +1	↓ +31	

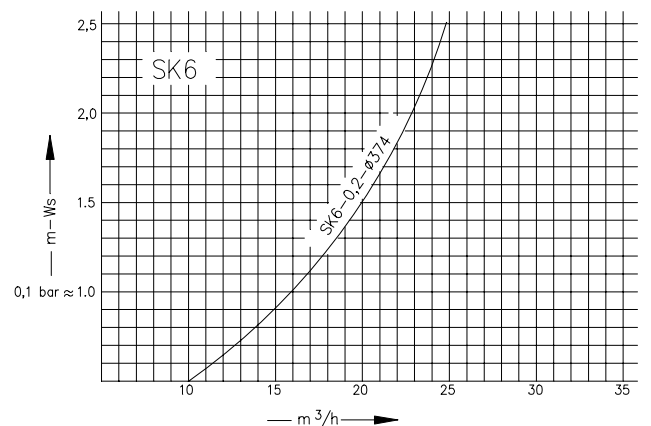

Filterdüsen-Sterne
mit 6 Armen

Filter-Nozzles-Stars
with 6 arms

Crépines étoiles
à 6 bras

Estrellas para
toberas a filtro
con 6 brazos

Typ SO6

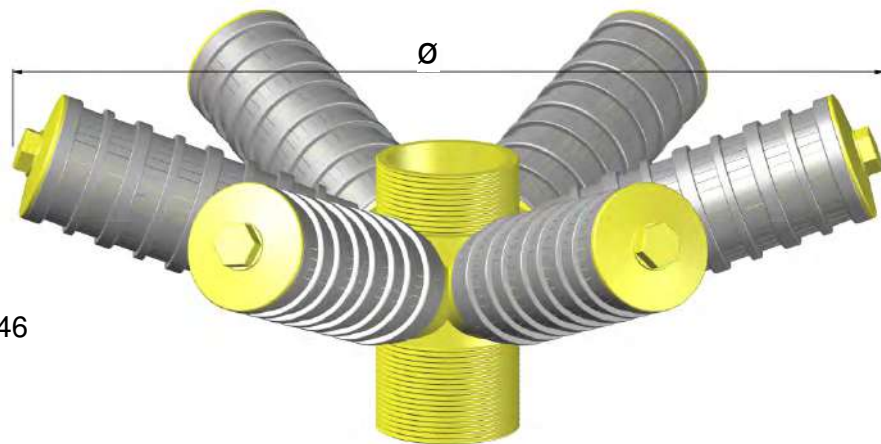

Typ A
Seite / Page 46

Typ MSO6

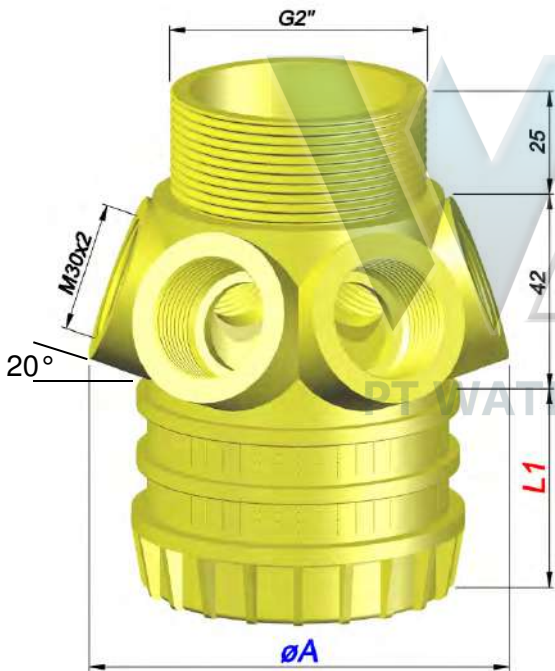

Typ MSO60

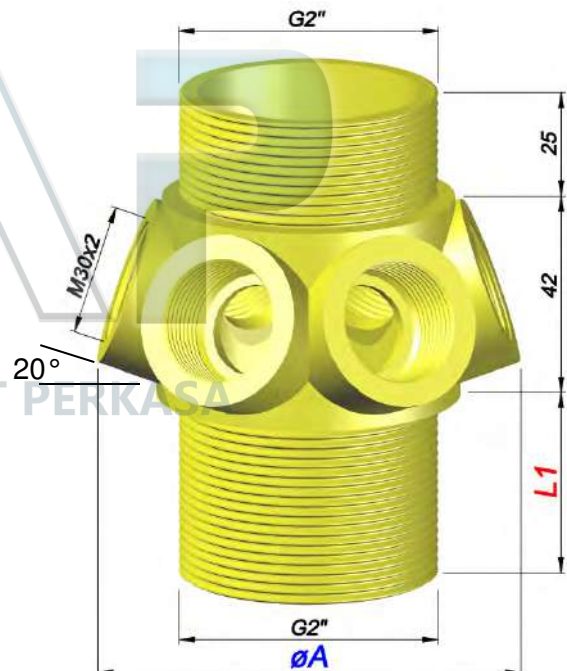

Bestellung Ordering Commande Encargo	Typ Type Type Tipa	L1	$\varnothing A$
	MSO60	25	98
		50	110

Bestellung Ordering Commande Encargo	Typ Type Type Tipa	L1	$\varnothing A$
	MSO6	20	98, 110
	MSO61	34	
	MSO62	46	
	MSO63	58	

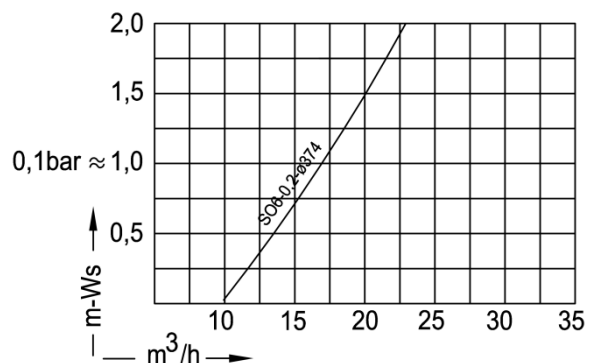

**Filterdüsen-Sterne
mit 6 Armen**

**Filter-Nozzles-Stars
with 6 arms**

**Crepines etoiles
avec 6 bras**

**Estrellas para
toberas a filtro
con 6 brazos**

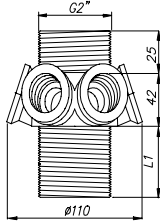

Bestellung Ordering Commande Encargo	Typ Type Type Tipa	L1
	MSO60	25 55

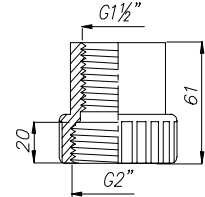

Bestellung Ordering Commande Encargo	Typ Type Type Tipa	Gewinde Thread Filetage Rosca
	GR2"	G 1 1/4"

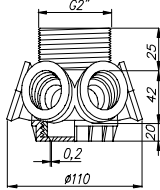

Bestellung Ordering Commande Encargo	Typ Type Type Tipa
	MSO6

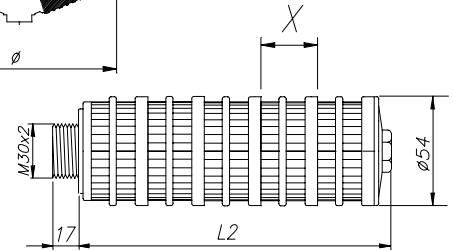
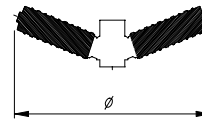

Bestellung Ordering Commande Encargo	Typ Type Type Tipa	Schlitze Slots Fentes Ranuras	X	L2	= Ø mm
	A	0,2 / 0,5	2 x	82	= Ø 258
		0,2 / 0,5	3 x	113	= Ø 316
		0,2 / 0,5	4 x	144	= Ø 374
		0,2 / 0,5	5 x	175	= Ø 432
		0,2 / 0,5	6 x	206	= Ø 491
		0,2 / 0,5	7 x	237	= Ø 549
		0,2 / 0,5	8 x	268	= Ø 607
		0,2 / 0,5	9 x	299	= Ø 665
		0,2 / 0,5	10 x	330	= Ø 724
		0,2 / 0,5	11 x	361	= Ø 782
		0,2 / 0,5	12 x	392	= Ø 840
		0,2 / 0,5	13 x	423	= Ø 898
		0,2 / 0,5	14 x	454	= Ø 957
		0,2 / 0,5	15 x	485	= Ø 1015
		0,2 / 0,5	16 x	516	= Ø 1073
		0,2 / 0,5	17 x	547	= Ø 1131
		" / "	↓ +1	↓ +31	= Ø + 62

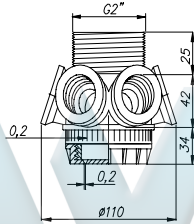

Bestellung Ordering Commande Encargo	Typ Type Type Tipa
	MSO61

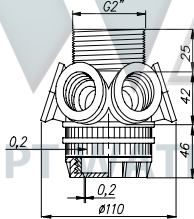

Bestellung Ordering Commande Encargo	Typ Type Type Tipa
	MSO62

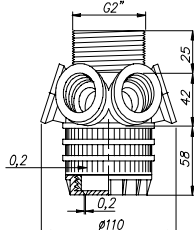

Bestellung Ordering Commande Encargo	Typ Type Type Tipa
	MSO63

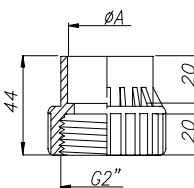

Bestellung Ordering Commande Encargo	Typ Type Type Tipa	ØA	Material Material Materiau Material
	GR2"	40 50 60,3 63	PVC

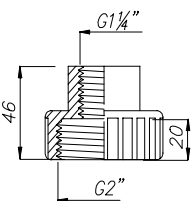
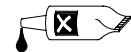

Bestellung Ordering Commande Encargo	Typ Type Type Tipa	Gewinde Thread Filetage Rosca
	GR2"	G 1 1/4"

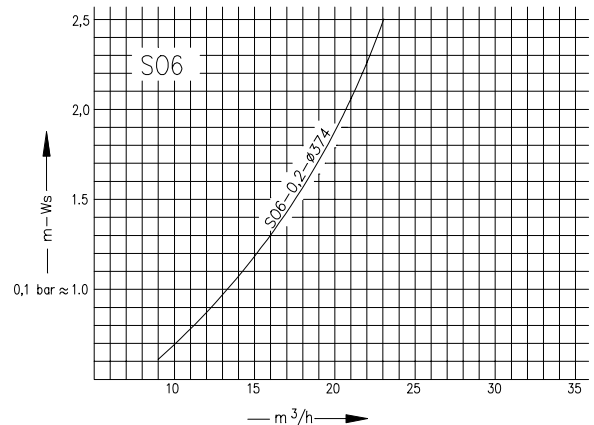

**Filterdüsen-Sterne
mit 8 Armen**

**Filter-Nozzles-Stars
with 8 arms**

**Crépines étoiles
à 8 bras**

**Estrellas para
toberas a filtro
con 8 brazos**

Typ SO8

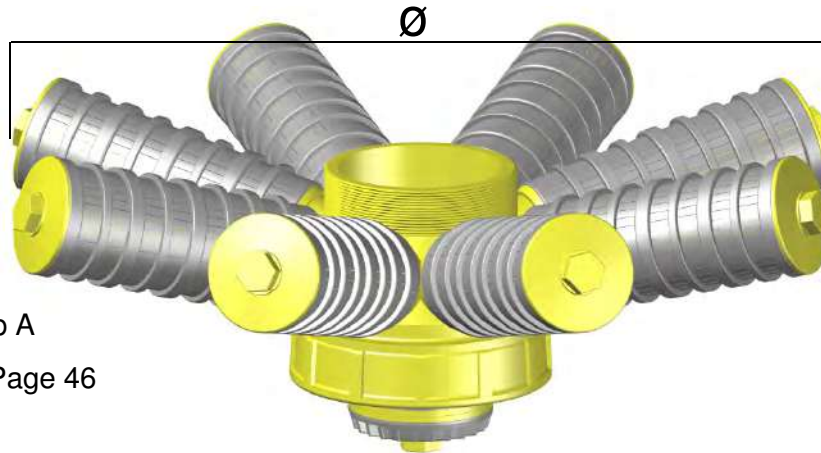

Typ A
Seite / Page 46

Typ MSO8

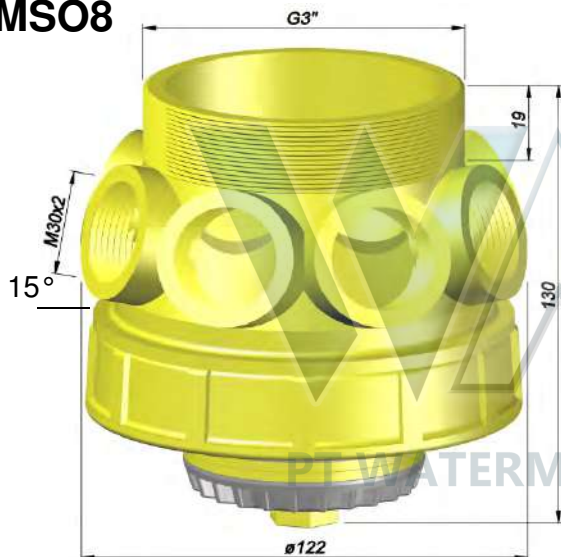

Bestellung Ordering Commande Encargo	Typ Type Type Tipa
---	-----------------------------



MSO8

Typ MSO16



Bestellung Ordering Commande Encargo	Typ Type Type Tipa
---	-----------------------------



MSO16

Typ GR3“

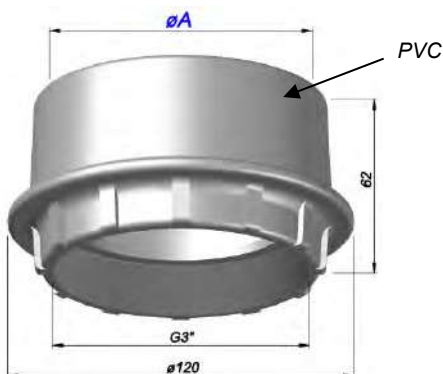

Bestellung Ordering Commande Encargo	Typ Type Type Tipa	øA
---	-----------------------------	-----------



GR3“

90

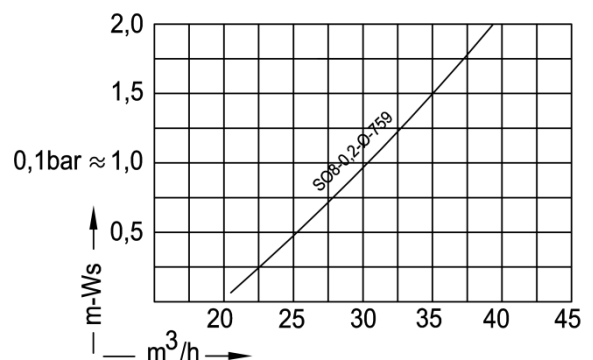

**Filterdüsen-Sterne
mit 8 Armen**

**Filter-Nozzles-Stars
with 8 arms**

**Crépines étoiles
à 8 bras**

**Estrellas para
toberas a filtro
con 8 brazos**

Typ SK8

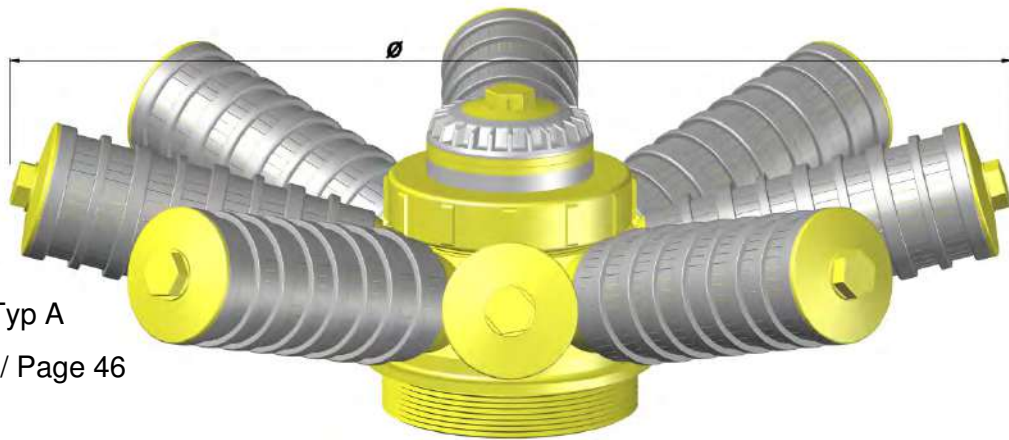

Typ A

Seite / Page 46

Typ MSK8

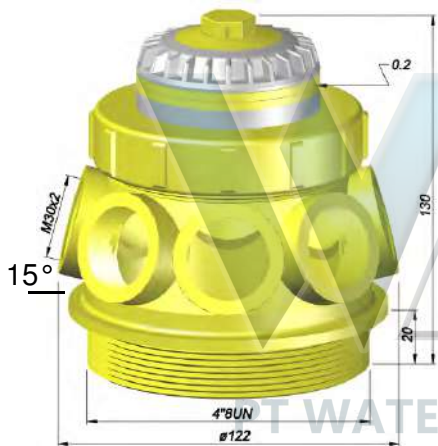

Typ MSK16



Bestellung Ordering Commande Encargo	Typ Type Type Tipa
	MSK8

Bestellung Ordering Commande Encargo	Typ Type Type Tipa
	MSK16

Typ GR4“-3“

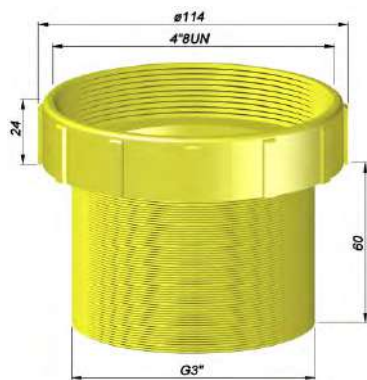

Typ ER3

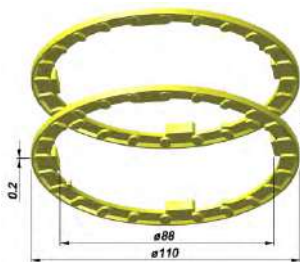

Bestellung Ordering Commande Encargo	Typ Type Type Tipa
	GR4“-3“

Bestellung Ordering Commande Encargo	Typ Type Type Tipa
	ER3

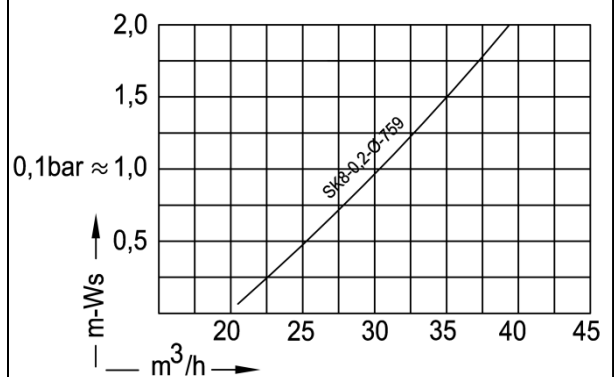

**Filterdüsen-Sterne
mit 8 Armen**

**Filter-Nozzles-Stars
with 8 arms**

**Crepines etoiles
avec 8 bras**

**Estrellas para
toberas a filtro
con 8 brazos**

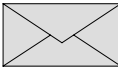

Bestellung Ordering Commande Encargo	Typ Type Type Tipa	Material Material Material Material
	MS8	PP

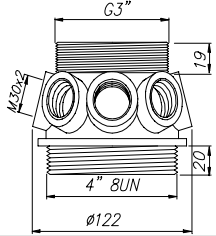

Technical drawing of MS8 nozzle star showing dimensions: 63" top diameter, 19" height, 4" 8UN thread, 20" bottom diameter, and 122mm overall diameter. Thread is M30x2.

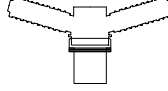

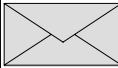
Bestellung Ordering Commande Encargo	Typ Type Type Tipa	Material Material Material Material
	ER3-0,2	PP

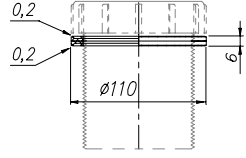

Technical drawing of ER3-0,2 nozzle star showing dimensions: 0,2" slot width, 0,2" slot depth, 110mm diameter, and 6mm height.



Bestellung Ordering Commande Encargo	Typ Type Type Tipa	Material Material Material Material
	MSK8	PP

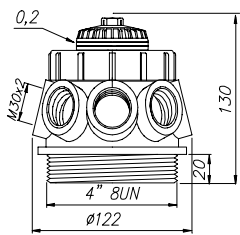

Technical drawing of MSK8 nozzle star showing dimensions: 0,2" slot width, 130" height, 4" 8UN thread, 20" bottom diameter, and 122mm overall diameter. Thread is M30x2.

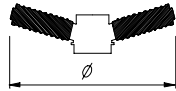
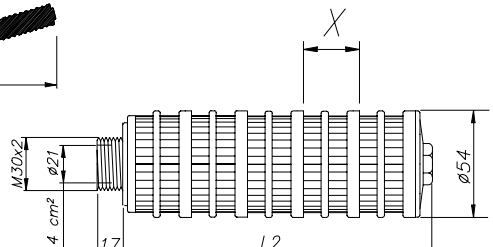
Technical drawing of nozzle star showing dimensions: X (slot width), L2 (length), 17mm bottom diameter, 54mm overall diameter, and 3,4 cm² area. Thread is M30x2.





Bestellung Ordering Commande Encargo	Typ Type Type Tipa	Material Material Material Material
	MSO8	PP

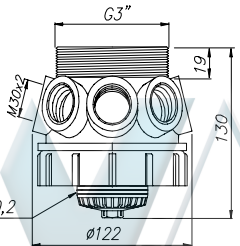

Technical drawing of MSO8 nozzle star showing dimensions: 63" top diameter, 19" height, 130" height, 4" 8UN thread, 20" bottom diameter, and 122mm overall diameter. Thread is M30x2.

Bestellung Ordering Commande Encargo	Typ Type Type Tipa	Schlitze Slots Fentes Ranuras	X	L2	= Ø mm
		0,2 / 0,5	6 x	206	= Ø 520
		0,2 / 0,5	7 x	237	= Ø 580
		0,2 / 0,5	8 x	268	= Ø 640
		0,2 / 0,5	9 x	299	= Ø 699
		0,2 / 0,5	10 x	330	= Ø 759
		0,2 / 0,5	11 x	361	= Ø 819
		0,2 / 0,5	12 x	392	= Ø 879
		0,2 / 0,5	13 x	423	= Ø 939
		0,2 / 0,5	14 x	454	= Ø 999
		0,2 / 0,5	15 x	485	= Ø 1059
		0,2 / 0,5	16 x	516	= Ø 1119
		0,2 / 0,5	17 x	547	= Ø 1179
		0,2 / 0,5	18 x	578	= Ø 1239
		0,2 / 0,5	19 x	609	= Ø 1299
		0,2 / 0,5	20 x	640	= Ø 1359
		0,2 / 0,5	21 x	671	= Ø 1419
		/	↓ +1	↓ +31	= Ø + 59,9



Bestellung Ordering Commande Encargo	Typ Type Type Tipa	Material Material Material Material
	GR3"-90	PVC

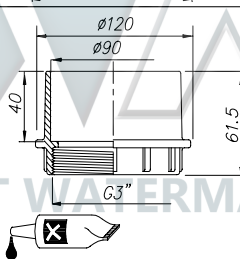

Technical drawing of GR3"-90 nozzle star showing dimensions: 120mm top diameter, 90mm middle diameter, 40mm height, 61.5mm total height, and 63" thread.



Bestellung Ordering Commande Encargo	Typ Type Type Tipa	Material Material Material Material
	VB4"-3"	PP

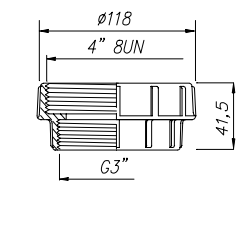

Technical drawing of VB4"-3" nozzle star showing dimensions: 118mm top diameter, 4" 8UN thread, 41.5mm height, and 63" thread.

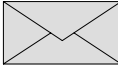

Bestellung Ordering Commande Encargo	Typ Type Type Tipa	Material Material Material Material
	GR4"-2"	PP

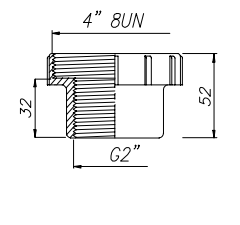

Technical drawing of GR4"-2" nozzle star showing dimensions: 4" 8UN thread, 32mm height, 52mm total height, and 62" thread.



Bestellung Ordering Commande Encargo	Typ Type Type Tipa	Material Material Material Material
	GR4"-3"	PP

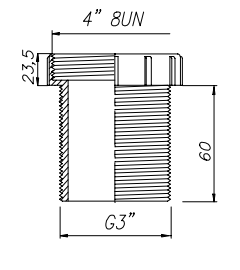

Technical drawing of GR4"-3" nozzle star showing dimensions: 4" 8UN thread, 23.5mm height, 60mm total height, and 63" thread.

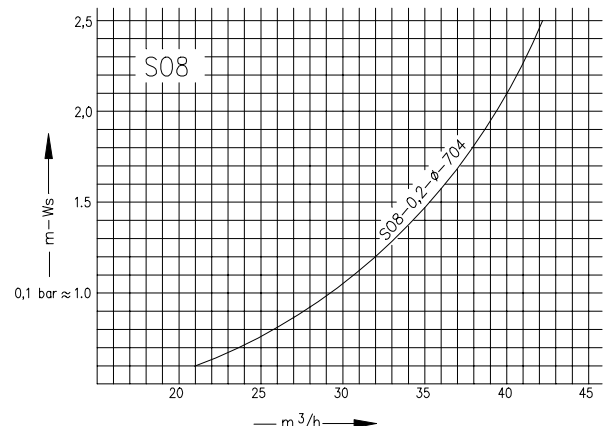

**Filterdüsen-Sterne
mit 6 Armen
für Flanschtank**

**Filter-Nozzles-Stars
with 6 arms
for Flange tank**

**Crépines étoiles
à 6 bras**

**Estrellas para
toberas a filtro
con 6 brazos**

Typ SK6F

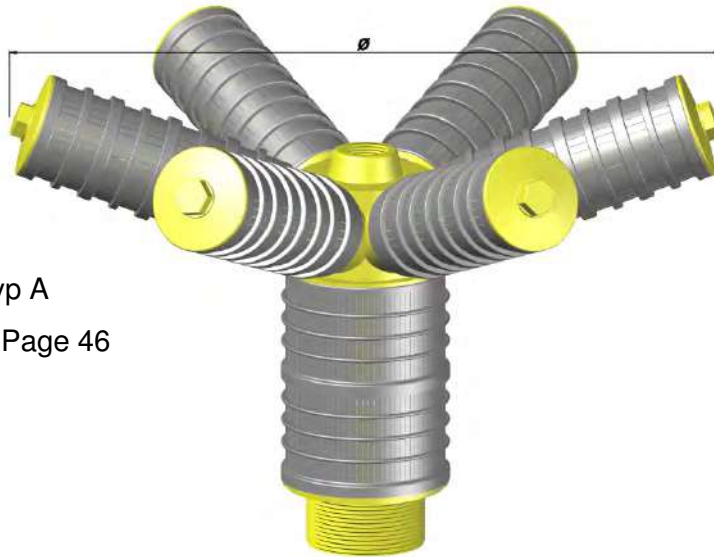

Typ A

Seite / Page 46

Typ MSK6F

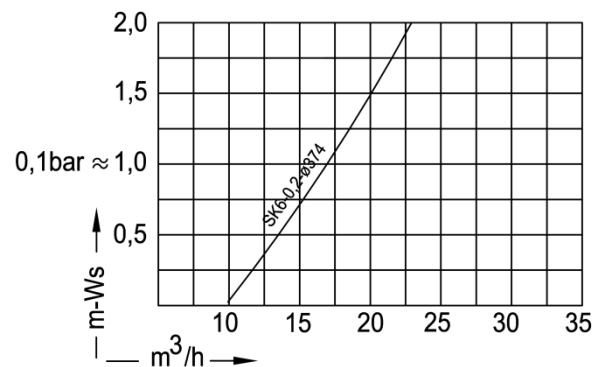
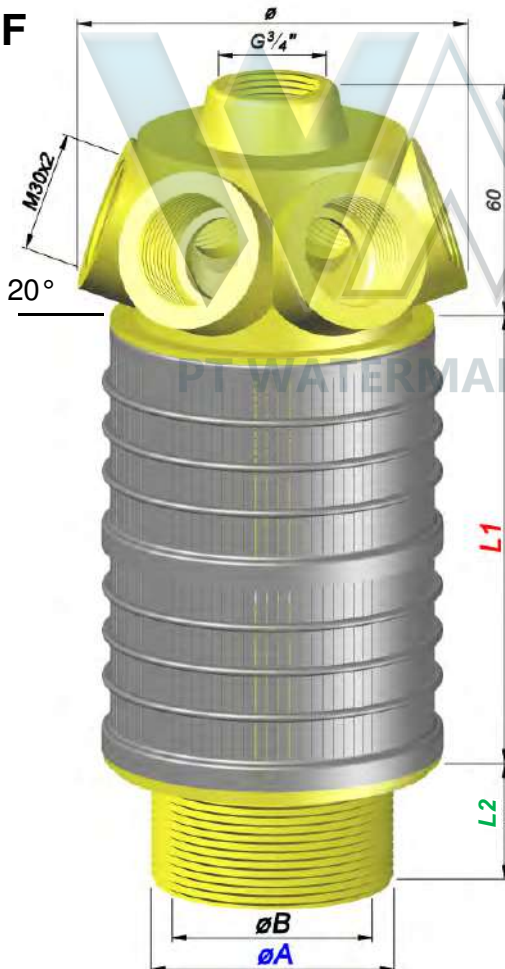

Bestellung Ordering Commande Encargo	Typ Type Type Tipa	Schlitze Slots Fentes Ranuras	Ø	ØA	ØB	L2	L1
✉	MSK6F	0,2	98	G 2"	Ø 50	33	64,
			110	G 2"	1 1/4"NPT		
		G 2"		1 1/2"NPT	116,		
		Ø 68		G 2"		170	
		2 1/2" 8NPSM	Ø60	20			

**Filterdüsen-Sterne
mit 8 Armen
für Flanschtank**

**Filter-Nozzles-Stars
with 8 arms
for Flange tank**

**Crépines étoiles
à 8 bras**

**Estrellas para
toberas a filtro
con 8 brazos**

Typ SK8F

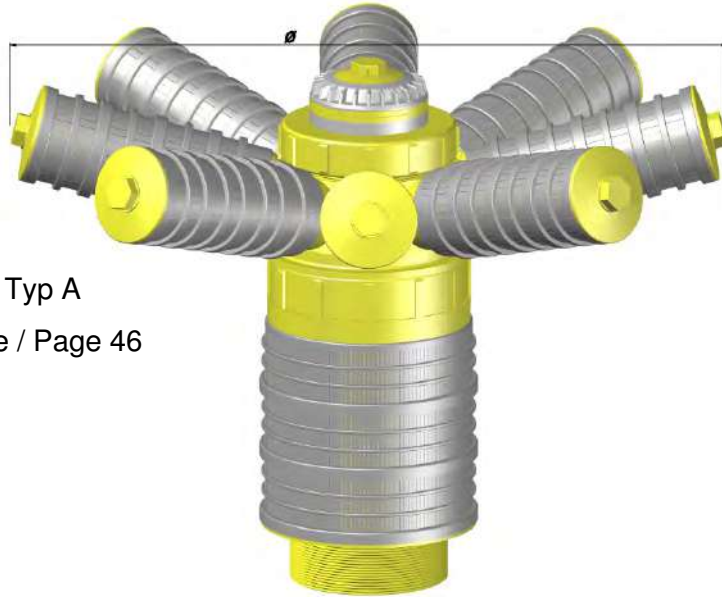

Typ A
Seite / Page 46

Typ MSK8F



Typ MSK16F

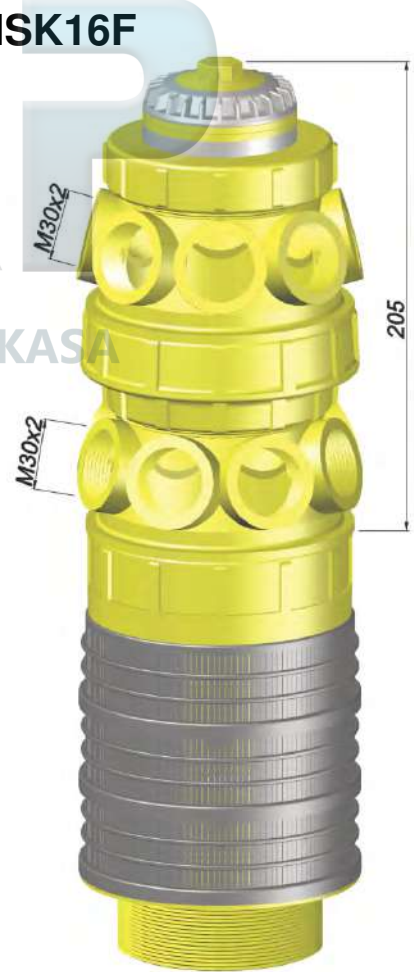

Bestellung Ordering Commande Encargo	Typ Type Type Tipa	Schlitze Slots Fentes Ranuras	ϕA	Länge Length Longueur Largura
✉	MSK8F	0,2	G 3"	115,
			3"NPT	150,
			4" 8UN	190,
				228

Bestellung Ordering Commande Encargo	Typ Type Type Tipa
✉	MSK16F

Adapter und Verbinder	Adapter and Connector	Adaptateur et raccord	Adaptador y conector
-----------------------	-----------------------	-----------------------	----------------------

Typ GR2“

Bestellung Ordering Commande Encargo	Typ Type Type Tipa	Gewinde Thread Filetage Rosca	
✉	GR2“	G 1 1/2“ G 1 1/4“	øA

Typ GR2“

Bestellung Ordering Commande Encargo	Typ Type Type Tipa	Gewinde Thread Filetage Rosca	
✉	GR2“	ø 40 ø 50 ø60,3 ø63	PVC

Typ GR3“

Bestellung Ordering Commande Encargo	Typ Type Type Tipa	Gewinde Thread Filetage Rosca	
✉	GR3“	ø 90 3" (US)	PVC

Adapter und Verbinder	Adapter and Connector	Adaptateur et raccord	Adaptador y conector
-----------------------	-----------------------	-----------------------	----------------------

Typ GR4“

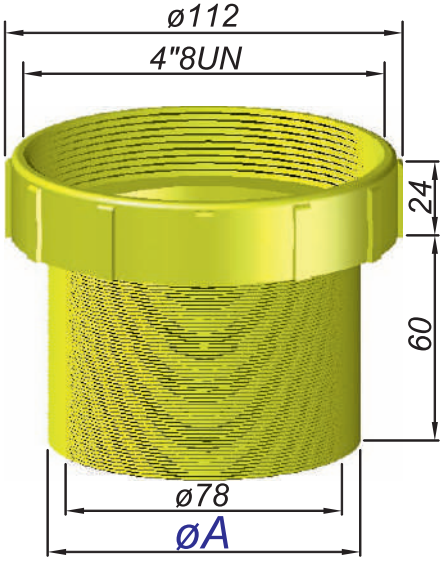

Bestellung Ordering Commande Encargo	Typ Type Type Tipa	Gewinde Thread Filetage Rosca	øA
	GR4“	G 3“	

Typ GR4“

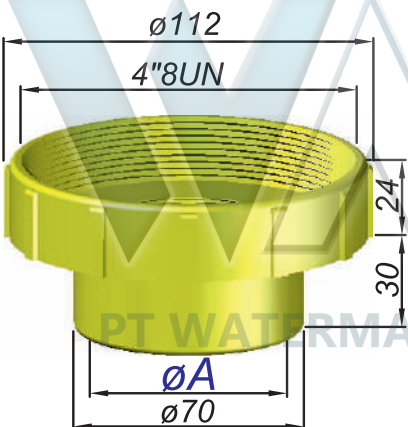

Bestellung Ordering Commande Encargo	Typ Type Type Tipa	Gewinde Thread Filetage Rosca	øA
	GR4“	G 2“	

Typ VB4“

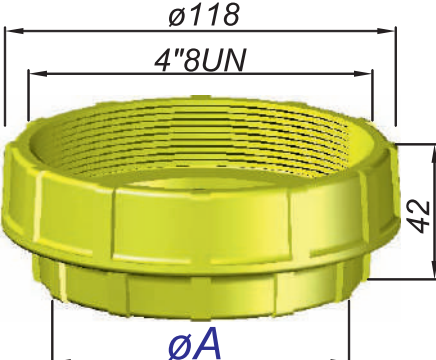

Bestellung Ordering Commande Encargo	Typ Type Type Tipa	Gewinde Thread Filetage Rosca	øA
	VB4“	G 3“	

Drainage-
system

Drainage
system

Système de
drainage

Systema de
drenaje

Typ SD3

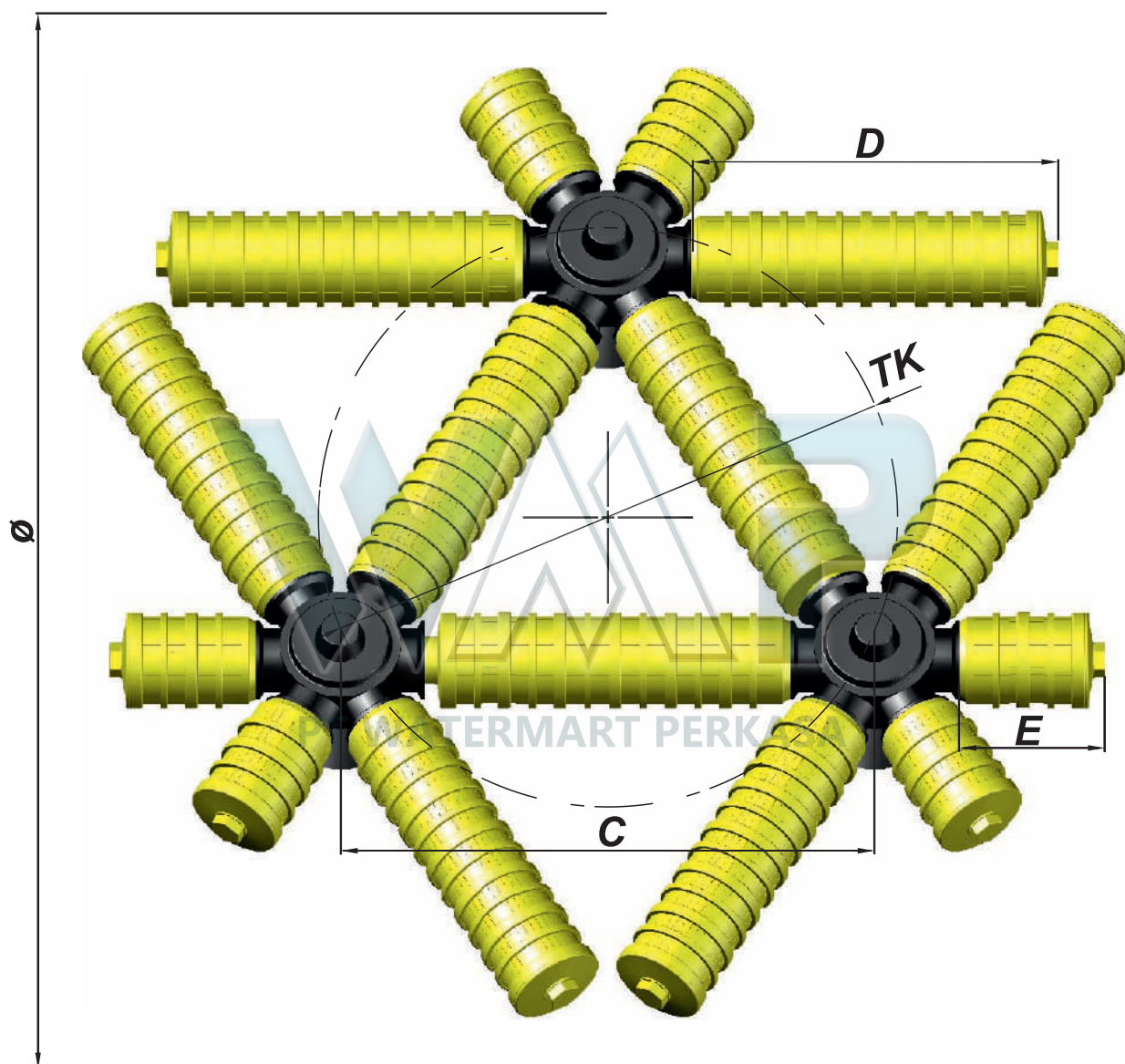

Bestellung Ordering Commande Encargo	Typ Type Type Tipa	Schlitze Slots Fentes Ranuras	Ø	TK	C	D	E
✉	SD3	0,2 0,5	600	308	265	175	82
			700	344	298	206	82
			800	416	362	268	144
			900	452	392	299	144
			1000	522	454	361	175
			1100	522	454	361	237
			1200	522	454	361	299

Drainage-
system

Drainage
system

Système de
drainage

Systema de
drenaje

Typ SD6

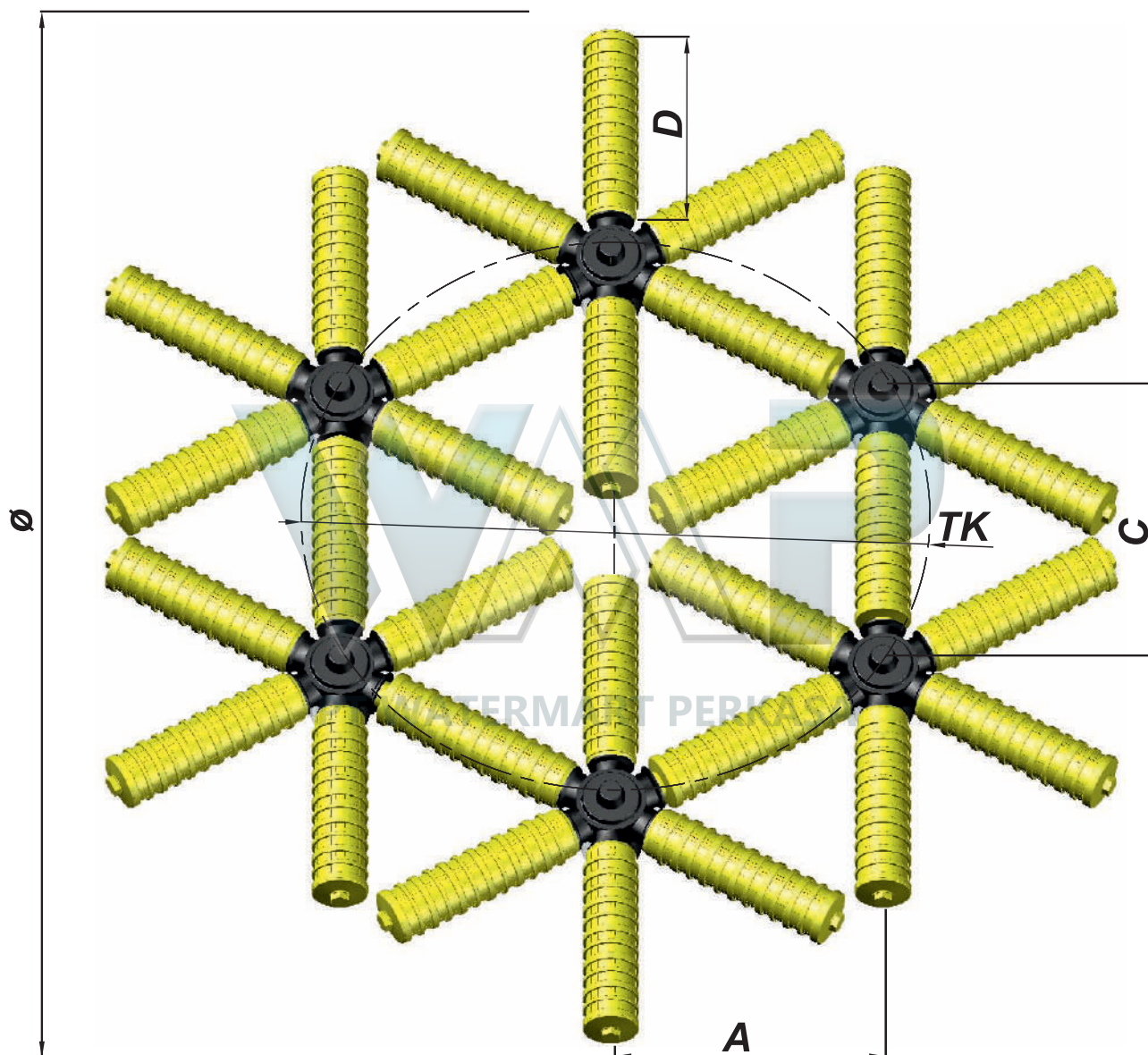

Bestellung Ordering Commande Encargo	Typ Type Type Tipa	Schlitze Slots Fentes Ranuras	\varnothing	TK	C	D	A
✉	SD6	0,2 0,5	800	408	204	113	176,7
			1000	536	268	175	232,1
			1200	600	300	206	259,8
			1300	664	332	237	287,5
			1400	728	364	268	315,2
			1500	788	394	299	341,2
			1700	852	426	330	368,9
			1800	912	456	361	394,9

Filterdüsen-Sterne mit 6 Armen	Filter-Nozzles-Stars with 6 arms	Crépines étoiles à 6 bras	Estrellas para toberas a filtro con 6 brazos
---	---	--	---

Typ SS6

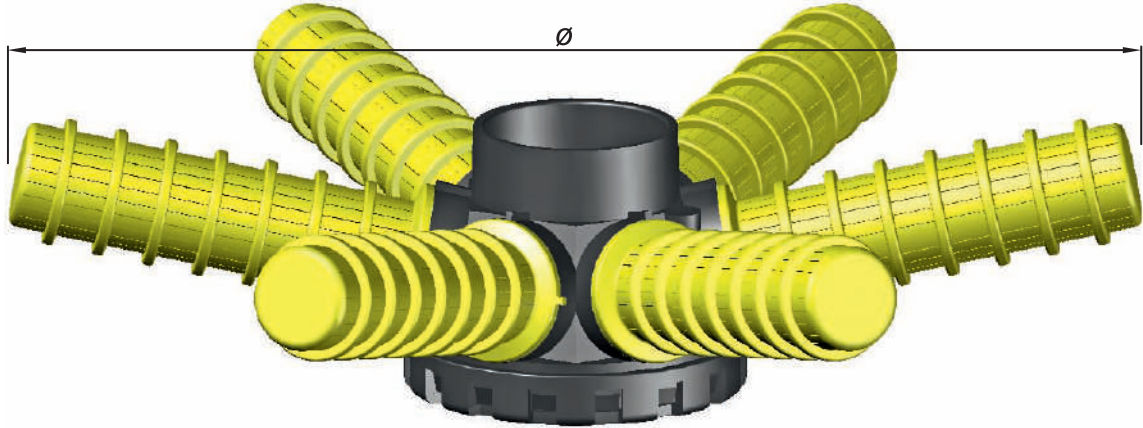

Typ MSS6

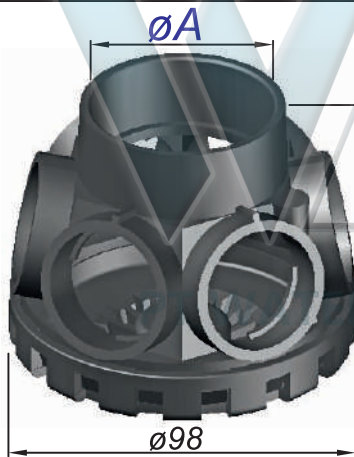

Bestellung Ordering Commande Encargo	Typ Type Type Tipa	ØA	Material Material Materiau Material
	MSS6	Ø 1.05" Ø 1" Ø 1¼" Ø 1.9" Ø 50	ABS

Typ A4

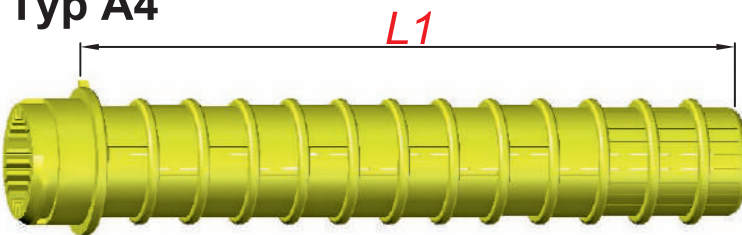

Bestellung Ordering Commande Encargo	Typ Type Type Tipa	Schlitze Slots Fentes Ranuras	L1	= Ø
	A4	0,25	143 = Ø 373 185 = Ø 460 210 = Ø 510	
teilweise geschlossen partially closed				

Typ A5

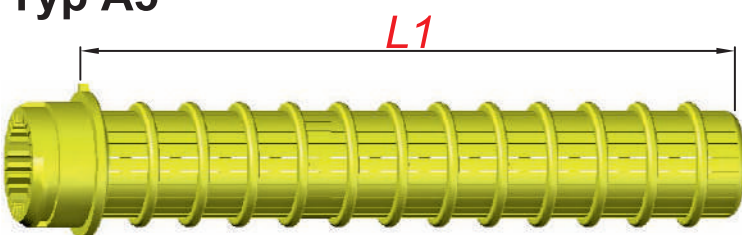

Bestellung Ordering Commande Encargo	Typ Type Type Tipa	Schlitze Slots Fentes Ranuras	L1	= Ø
	A5	0,25	85 = Ø 260 113 = Ø 314 143 = Ø 373 185 = Ø 460 210 = Ø 510	

Filterdüsen-Sterne
mit 8 Armen

Filter-Nozzles-Stars
with 8 arms

Crépines étoiles
à 8 bras

Estrellas para
toberas a filtro
con 8 brazos

Typ SS8

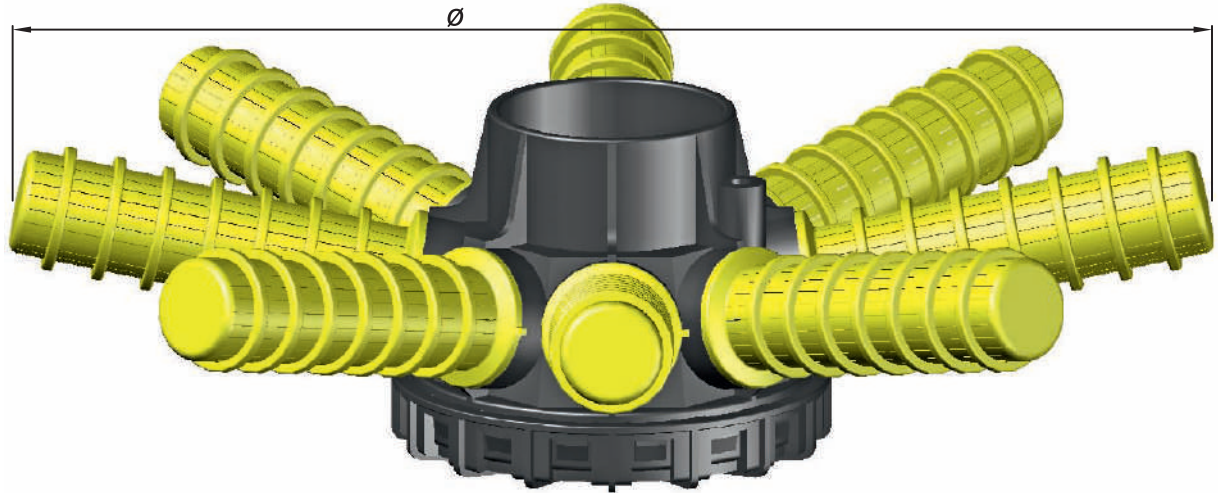

Typ MSS8

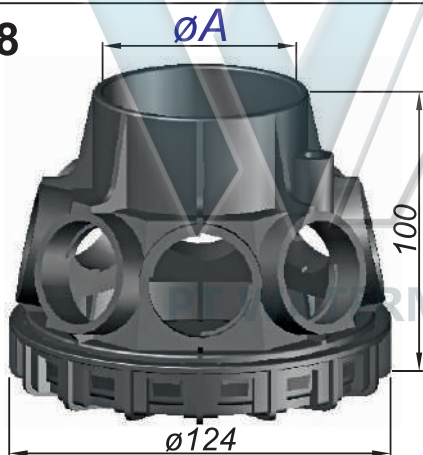

Bestellung Ordering Commande Encargo	Typ Type Type Tipa	Ø A	Material Material Material Material
	MSS8	Ø 60,3 Ø 63	ABS

Typ A4

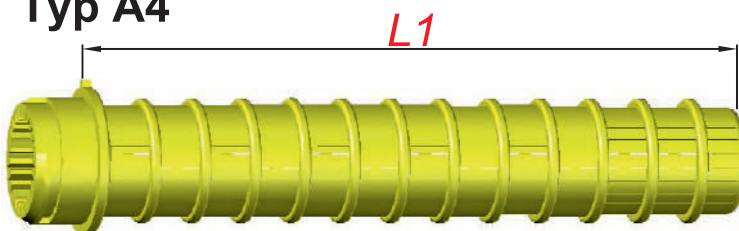

Bestellung Ordering Commande Encargo	Typ Type Type Tipa	Schlitze Slots Fentes Ranuras	L1	= Ø
	A4	0,25	143	= Ø 397
			185	= Ø 479
			210	= Ø 532
		teilweise geschlossen partially closed		

Typ A5

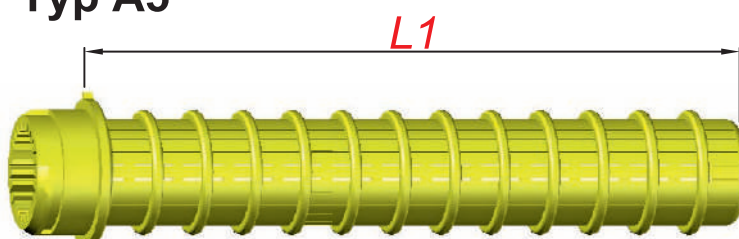

Bestellung Ordering Commande Encargo	Typ Type Type Tipa	Schlitze Slots Fentes Ranuras	L1	= Ø
	A5	0,25	85	= Ø 284
			113	= Ø 338
			143	= Ø 397
			185	= Ø 479
			210	= Ø 532
			240	= Ø 586
			270	= Ø 644
			312	= Ø 726

Filterdüsen- Arme	Filter-Nozzles Arms	Crépines bras	Brazos de toberas a filtro
----------------------	------------------------	---------------	-------------------------------

Typ SSR

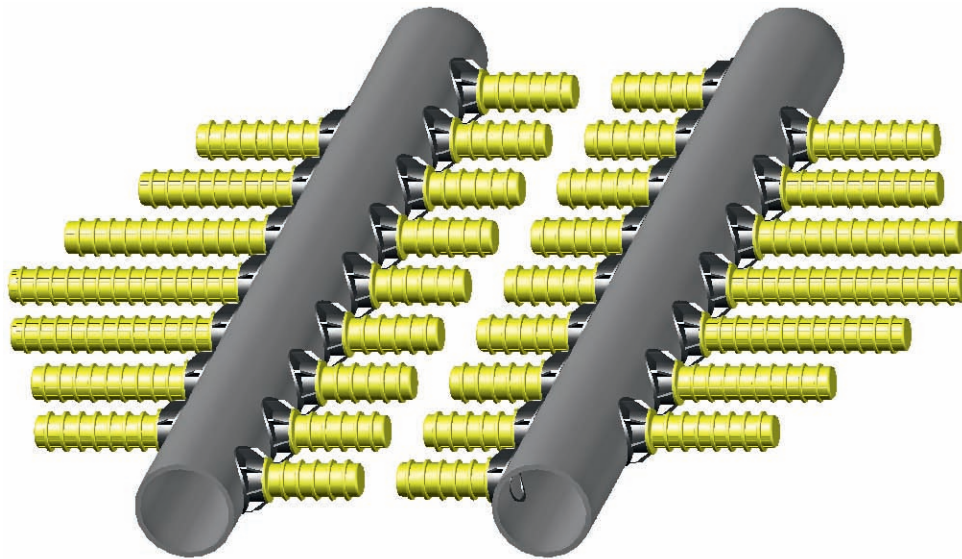

Typ SSR

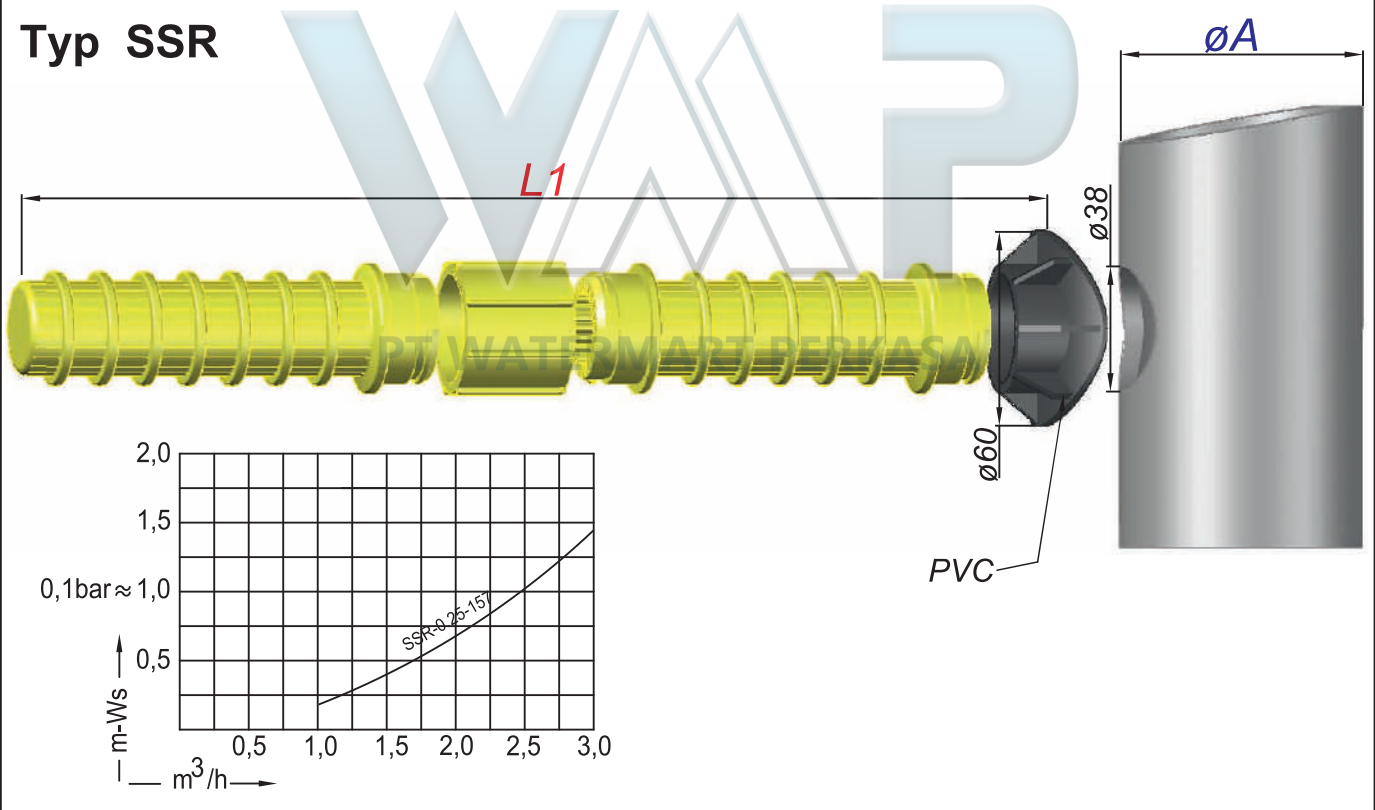

Bestellung Ordering Commande Encargo	Typ Type Type Tipa	Schlitze Slots Fentes Ranuras	$\varnothing A$	L1	Länge Length Longueur Largura
	SSR	0,25	$\varnothing 63$ $\varnothing 75$ $\varnothing 90$ $\varnothing 114$	L1	99, 127, 157, 199, 224, 254, 284, 326, 351, 381, 411, 453, 480, 508, 538, 580, 607, 635, 665, 707, 734, 762, 792, 834, 861, 889, 919, 961, 988, 1016, 1046, 1088 ...

Filterdüsen-
Arme

Filter-Nozzles
Arms

Crépines bras

Brazos de toberas
a filtro

Typ A3

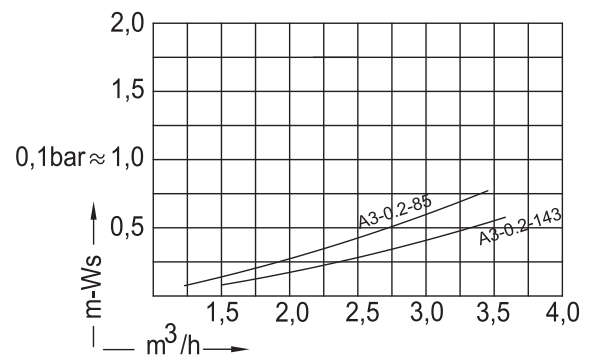
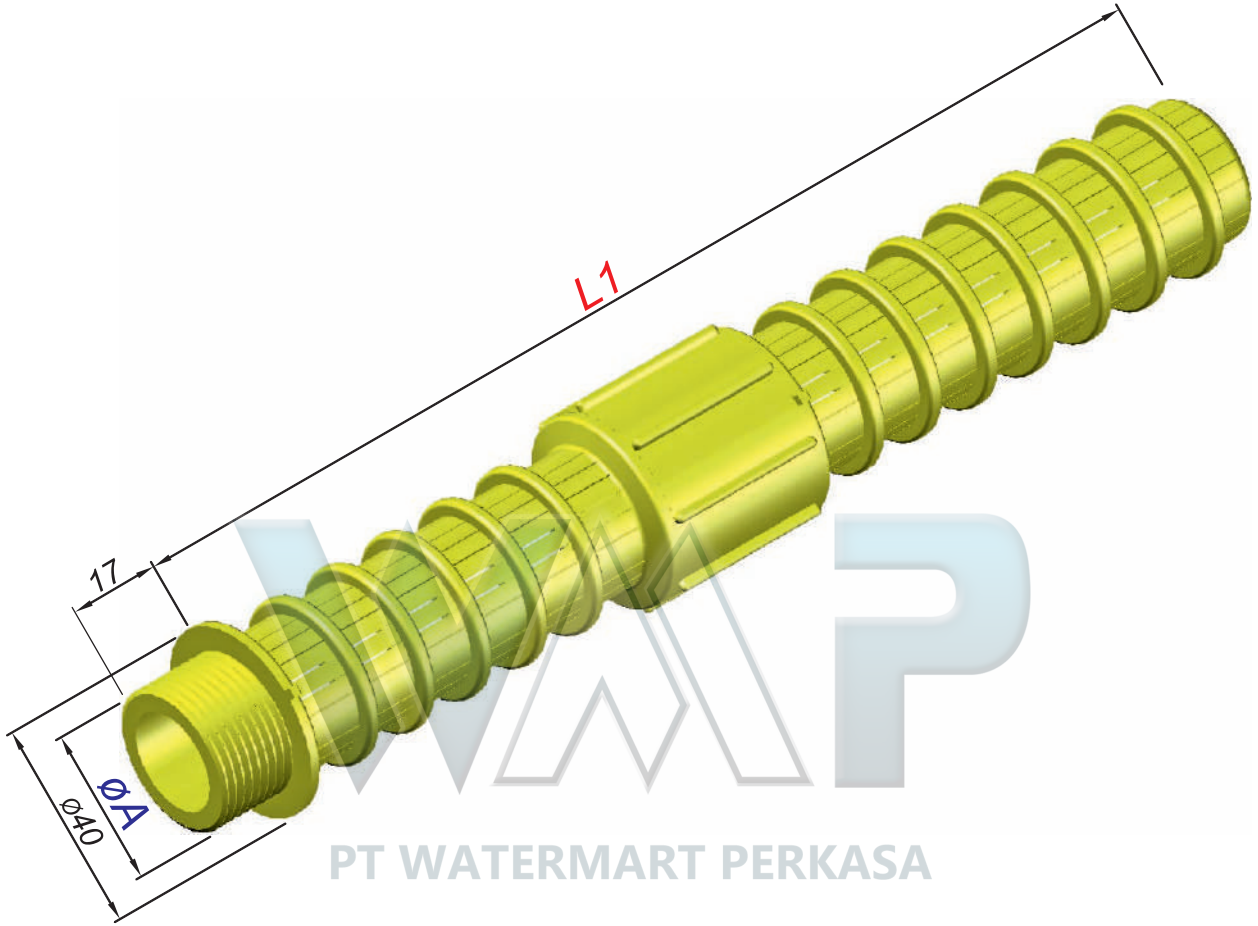

Bestellung Ordering Commande Encargo	Type Type Type Tipa	Schlitze Slots Fentes Ranuras	Gewinde Thread Filetage Rosca	ϕA	Länge Length Longueur Largura	L1
	A3	0,25	G 3/4"		212, 240, 270, 312, 337, 367, 397, 439, 464, 494, 524, 566, 591, 621, 651, 693, 820, 947, 1074, ...	
			M30x2			
			G 1"		85, 113, 143, 185, 210, 240, 270, 312, 337, 367, 397, 439, 464, 494, 524, 566, 591, 621, 651, 693, 820, 947, 1074, ...	

Typ HSD

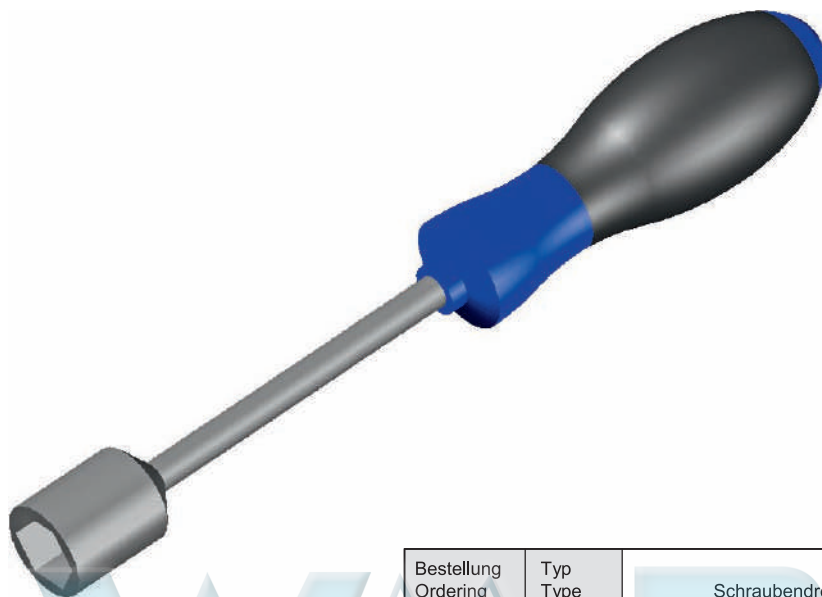

Bestellung Ordering Commande Encargo	Typ Type Type Tipa	Schraubendreher Screwdriver
	HSD	SW17

Typ DSD



Bestellung Ordering Commande Encargo	Typ Type Type Tipa	Drehmoment - Schraubendreher Torque screwdriver Tournevis à déclenchement Atornillador con limitador de par
	DSD	SW17 3-6 Nm

Beispiele
Sonderanfertigungen
auf Anfrage
Zum Download:
www.ksh-filter.de

Examples for
special-design
on request
For Download:
www.ksh-filter.de

Exemples de
fabrication spéciale
sur demande
Pour Télécharger:
www.ksh-filter.de

Ejemplos de
fabricaciones especial
sobre demanda
Para Descargar:
www.ksh-filter.de

DSR

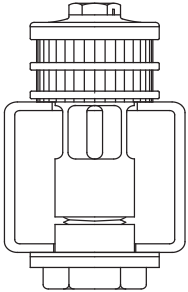

KE

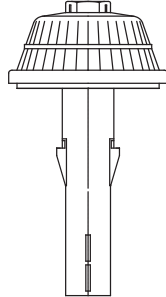

R2DB

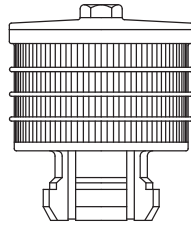

G2

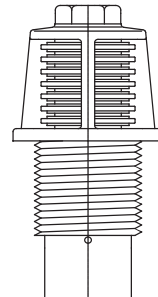

KSPB

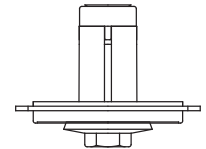

LB

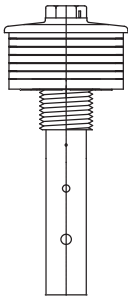

LB2

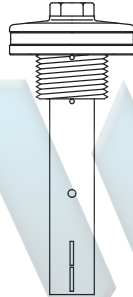

MST



RSP

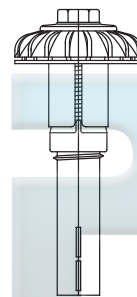

MV

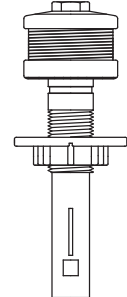

S2DB

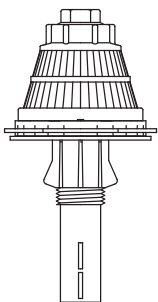

S2GR

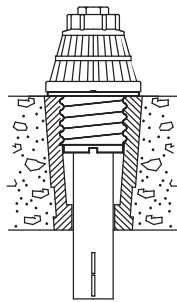

CA

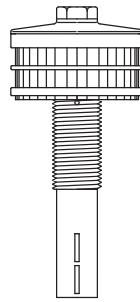

SLR

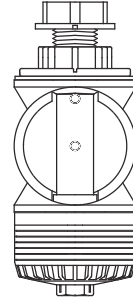

DD

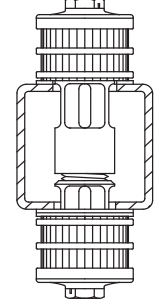

SCR

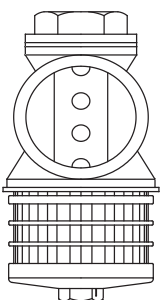

VP

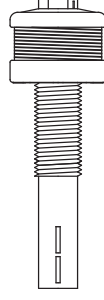

S2/S2

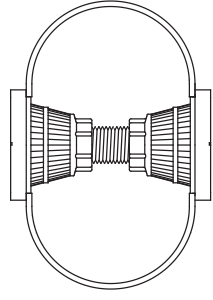

Lanzen

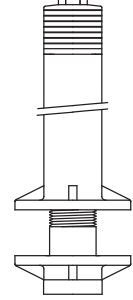

LCR

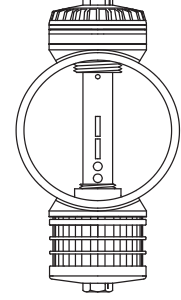

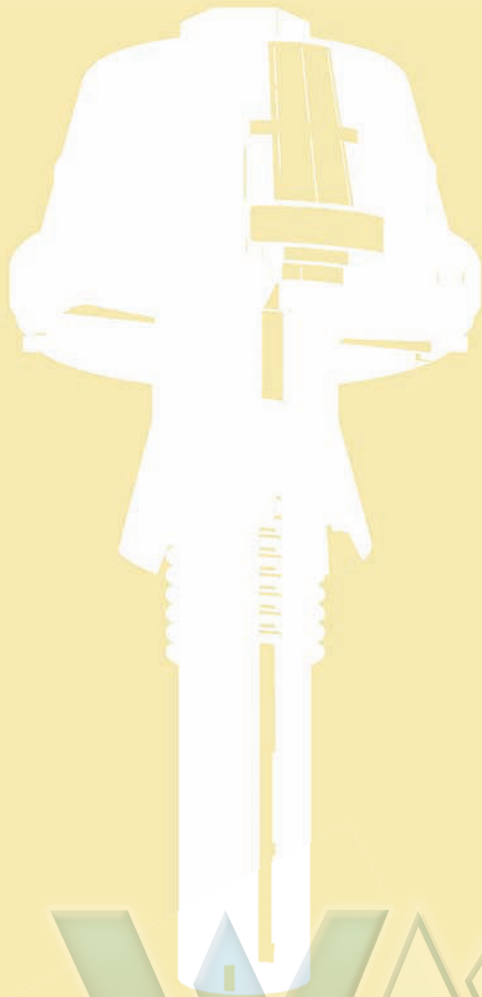

WAP

PT WATERMART PERKASA

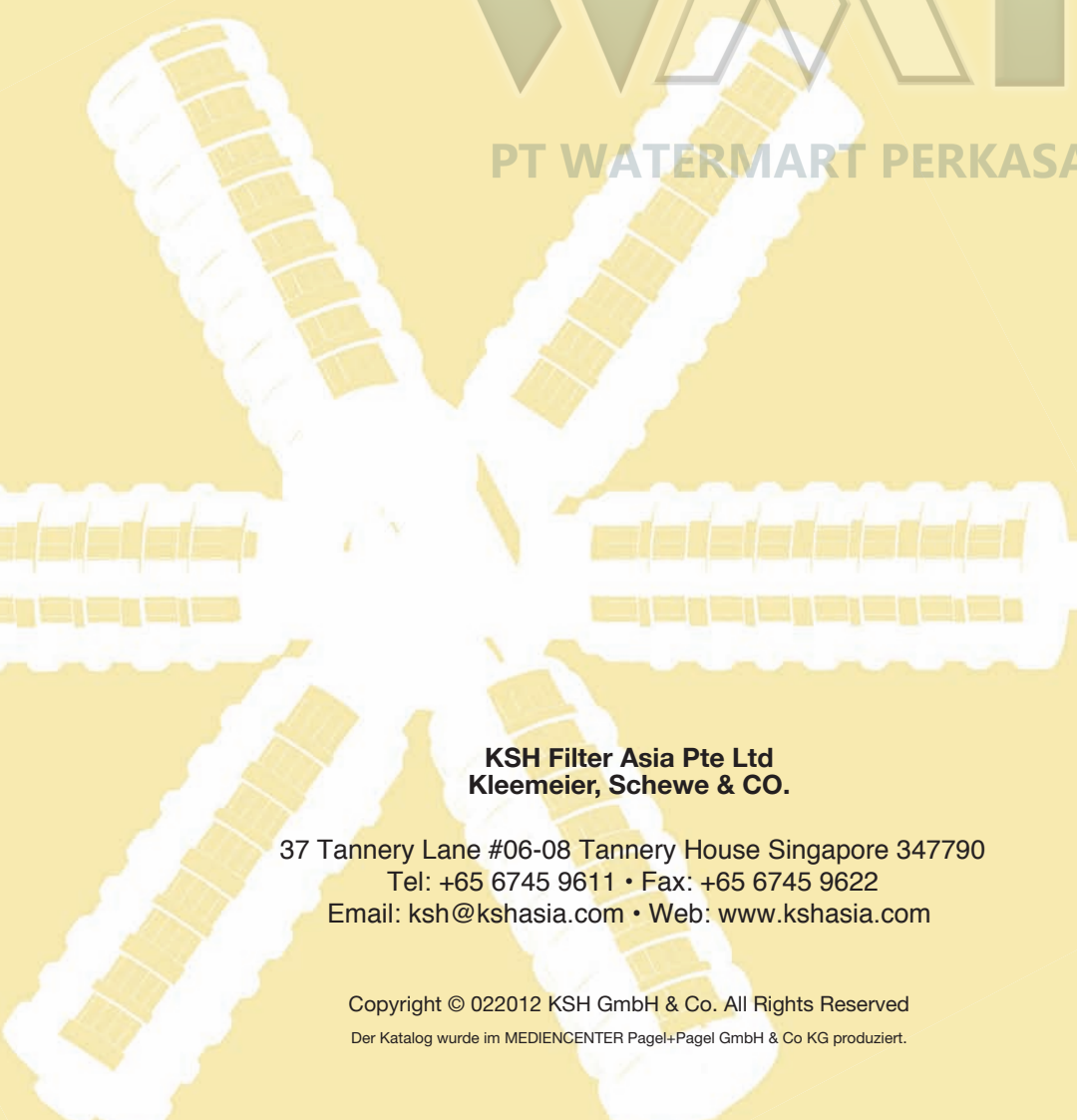

KSH Filter Asia Pte Ltd
Kleemeier, Schewe & CO.

37 Tannery Lane #06-08 Tannery House Singapore 347790

Tel: +65 6745 9611 • Fax: +65 6745 9622

Email: ksh@kshasia.com • Web: www.kshasia.com

Copyright © 022012 KSH GmbH & Co. All Rights Reserved

Der Katalog wurde im MEDIENCENTER Pagel+Pagel GmbH & Co KG produziert.

KSH

